

# TABLE OF CONTENTS

SERIES 5700 SINGLE HUNG .....	2
SERIES 130 SINGLE HUNG .....	6
SERIES 150/160 SINGLE HUNG .....	14
SERIES 450/460 DOUBLE HUNG .....	20
HORIZONTAL SLIDERS .....	26
SERIES 5700 SLIDERS.....	27
SERIES 130 SLIDERS.....	29
SERIES 151/161 SLIDERS .....	36
SERIES 451/461 SLIDERS.....	40
CASEMENT WINDOWS.....	44
AWNING.....	49
SLIDING PATIO DOORS .....	51

# SERIES 5700 SINGLE HUNG

## Features:

- Removable bottom sash
- Industry leading .01 cfm/ft. air infiltration performance
- 1 1/4" Nail-fin setback for brick veneer construction and select stucco applications
- Sweep lock helps provide a weather-tight seal and added security
- Versatile half screen\* installs easily from inside
- Sloped sill reduces air infiltration and accommodates easy water run-off
- Built-in accessory channels accommodate multiple installation options
- Block and Tackle Balance System for ease of operation
- Limited lifetime warranty provides reassuring peace of mind
- Pre-punched integral nail-fin targets proper nail location for quick, easy installation
- Modular sized so that rough opening widths for multiple units are easy to calculate:  
 5700 Single=35.5"  
 5700 Twin=71.5"  
 5700 Triple=107.5"
- DP Ratings:  
 R35 (window size tested 44" x 96")  
 R25 (window size tested 48" x 96")
- Jamb depth: 2.625"

## Custom Options:

- Low-E Glass.
- Low-E Glass with Argon Gas.
- Ultra Low-E Glass with Argon Gas.
- 5/8" or 3/4" flat, 5/8" or 1" contoured, 5/8" contoured valance grids available.
- Factory mulling of twins, triples and architectural shapes.
- Custom sizes available.
- Window Opening Control Device (WOCD) for fall prevention (field applied).
- Paintable or stainable wood jamb extensions (4 9/16" and 6 9/16").

## Materials:

- Frame and sash are maintenance free, color stabilized solid vinyl (PVC).
- The screen is comprised of rolled form aluminum frame and fiberglass mesh.
- Glazing method: Glazing tape.

## Structural Performance

SERIES/MODEL	TEST SIZE	AIR (cfm/ft <sup>2</sup> )	DESIGN PRESSURE
5700 SH	36 X 96	0.1	H-LC50
5700 CHS SHTW	84 X 84	0.02	H-LC35
5700 CHS SHTR	108 X 84	0.17	H-LC40

## Thermal Performance

GLASS/GRID	U-Value	SHGC
SS Clear Glass No Grid	0.49	0.66
DS Clear Glass No Grid	0.49	0.64
SS Low-E Glass No Grid	0.34	0.31
DS Low-E Glass No Grid	0.34	0.31
SS Low-E/Argon Glass No Grid	0.31	0.31
DS Low-E/Argon Glass No Grid	0.30	0.31
SS Ultra Low-E No Grid	0.34	0.23
DS Ultra Low-E No Grid	0.34	0.23
SS Ultra Low-E/Argon No Grid	0.30	0.23
DS Ultra Low-E/Argon No Grid	0.30	0.23

GLASS/GRID	U-Value	SHGC
SS Clear Glass with Grid	0.49	0.59
DS Clear Glass with Grid	0.49	0.58
SS Low-E Glass with Grid	0.34	0.28
DS Low-E Glass with Grid	0.34	0.28
SS Low-E/Argon Glass with Grid	0.31	0.28
DS Low-E/Argon Glass with Grid	0.30	0.28
SS Ultra Low-E with Grid	0.34	0.21
DS Ultra Low-E with Grid	0.34	0.21
SS Ultra Low-E/Argon with Grid	0.30	0.21
DS Ultra Low-E/Argon with Grid	0.30	0.21

# SERIES 5700 SINGLE HUNG

SERIES	5700 SH
VINYL WALL THICKNESS	0.062"
GLASS THICKNESS	0.750"
JAMB THICKNESS	2.625"
FRAME WIDTH	1.3125"
NAILING FIN LENGTH	1.125"
NAIL FIN SETBACK	1.375"
EGRESS WIDTH	(WW) - 2.625"
EGRESS HEIGHT (WITH SASH)	(WH/2) - 4.75"
SCREEN WIDTH	(WW) - 1.4375"
SCREEN HEIGHT	(WH/2) - .4375"
<b>OPTIONS GLASS:</b>	
CLEAR (STANDARD)	•
LOW-E ARGON	•
ULTRA LOW-E WITH ARGON	•
OBSCURE	•
TEMPERED	•
DOUBLE STRENGTH	•
TINTED (GRAY AND BRONZE)	•
SPECIALTY DARK	•
SPECIALTY DARK WITH ARGON	•
<b>OPTIONS GAS:</b>	
ARGON	•
<b>AVAILABLE SPECIAL SHAPES:</b>	
FULL ROUNDS	QUARTER ROUNDS
HALF ROUNDS	ELLIPTICALS
OCTAGONS	PENTAGONS
TRAPEZOIDS	TRIANGLES
HALF EYEBROWS	EYEBROWS
COLONIAL ARCHES	COLONIAL FLANKERS
OVALS	COLONIAL ARCH FLANKERS
OPERABLE EYEBROWS	OPERABLE HALF EYEBROWS
<b>COLOR:</b>	
WHITE	•
ALMOND	•

(WW) = WINDOW WIDTH  
 (WH) = WINDOW HEIGHT

## Series 5700 SH vertical diagram

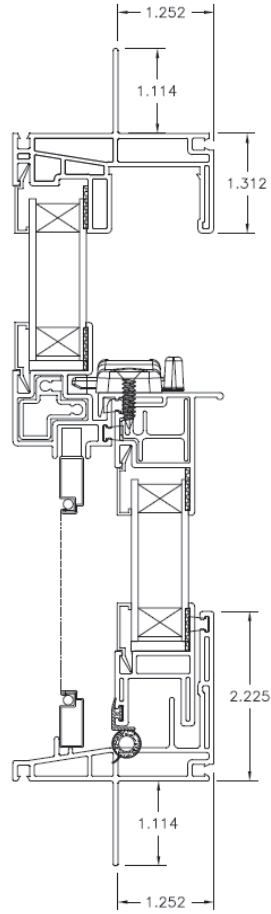

## Series 5700 SH horizontal diagram

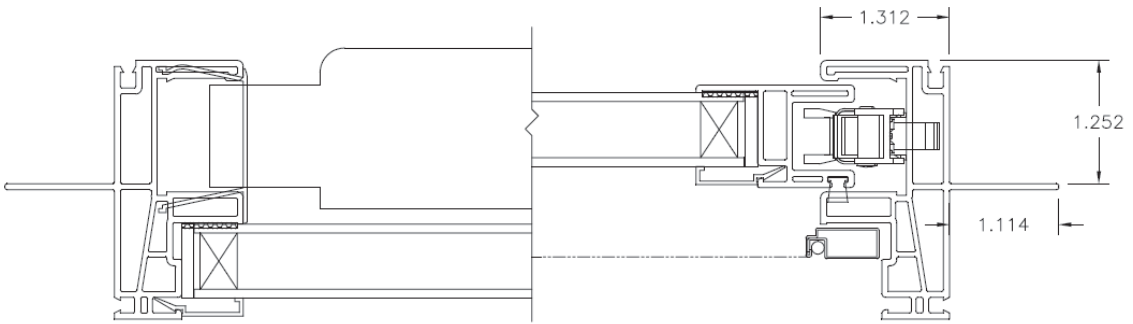

## Mulled Units:

Factory mulling of twins, triples and special shapes provides easier installation without extra labor or material costs.

Reinforcement is available for added strength in factory mulled units.

**Series 5700**

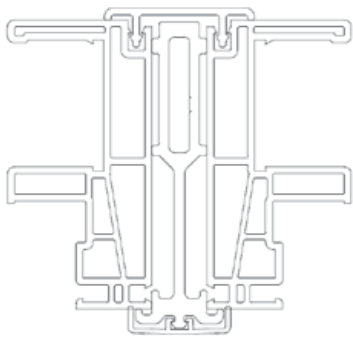

## Recommended Rough Opening:

Width = Window Width (WW) + 1/2"

Height = Window Height (WH) + 1/2"

---

## Wood-Jamb Extension:

The interior wood-jamb extension is available in pre primed or stainable version for your convenience and ease of installation for a frame thickness of either 4 9/16" or 6 9/16".

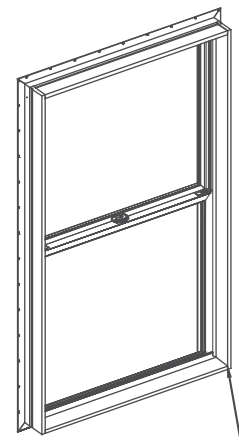

WOOD EXTENSION 3" X 5/8"  
OVERALL WALL THICKNESS = 4 9/16"

# SERIES 130 SINGLE HUNG

## Features:

- Bottom sash tilts in for easy cleaning from inside.
- Aluminum half screen comes standard.\*
- Block & tackle balance system for easy sash movement.
- Warm-Edge spacer system provides energy saving thermal performance.
- DP 50 rating (window size tested 53" x 77").
- Aluminum reinforcement standard in lock & meeting rails and sash stiles.
- Dual Sweep locks (standard at 27 1/4" and above) help provide a weather-tight seal and added security.
- Step sill design combines water run-off and aesthetic features of a sloped sill with the structural strength and internal drainage system of a pocket sill.
- Jamb depth: 3".
- Limited lifetime warranty.
- DP Rating R50 (window size tested 53" x 77")

## Select from four frame types:

- Front Flange Only
- Nail Fin Only (no J-Channel)
- J-Channel (nail fin & front flange)
- Box Frame (no nail fin & no front flange)

## Custom Options:

- Low-E Glass.
- Low-E Glass with Argon Gas.
- Ultra Low-E Glass with Argon Gas.
- 5/8" or 3/4" flat, 5/8" or 1" contoured and 1 1/8" Simulated Divide Lite (SDL) available
- Non-reflective Low-E Glass and Non-reflective Low-E Glass with Argon Gas.
- Double strength and obscure glass.
- Oriel style.
- Window Opening Control Device (WOCD) for fall prevention (factory applied).
- Factory mulling and Factory Prepared mulling.
- Commodity sizing available.
- Custom sizes available.
- Charcoal Aluminum half screen.

## Materials:

- Frame and sash are maintenance free, color stabilized solid vinyl (PVC).
- The screen is comprised of rolled form aluminum frame and fiberglass mesh.

## Structural Performance

SERIES/MODEL	TEST SIZE	AIR (cfm/ft <sup>2</sup> ...)	DESIGN PRESSURE
130 SH	53 X 77	0.13	H-LC50
130 SH WITH TRANSOM	48 X 109	0.17	H-LC50
130 SHTW WITH TRANSOM	73 X 109	0.13	H-LC50
130 SHTR	109 X 77	0.19	H-LC50
130 SHTW	97 X 84	0.13	H-LC40

## Thermal Performance

GLASS/GRID	U-Value	SHGC
SS Clear Glass No Grid	0.49	0.63
DS Clear Glass No Grid	0.49	0.62
SS Low-E Glass No Grid	0.36	0.30
DS Low-E Glass No Grid	0.35	0.30
SS Low-E/Argon Glass No Grid	0.32	0.30
DS Low-E/Argon Glass No Grid	0.32	0.29
SS Ultra Low-E/Argon No Grid	0.29	0.22
DS Ultra Low-E/Argon No Grid	0.29	0.22
SS Turtle Code Low-E No Grid	0.36	0.21
DS Turtle Code Low-E No Grid	0.36	0.21
SS Turtle Code Low-E/Argon No Grid	0.33	0.20
DS Turtle Code Low-E/Argon No Grid	0.33	0.20
SS Clear Glass with Grid	0.49	0.57
DS Clear Glass with Grid	0.49	0.55
SS Low-E Glass with Grid	0.36	0.27
DS Low-E Glass with Grid	0.35	0.27

GLASS/GRID	U-Value	SHGC
SS Low-E/Argon Glass with Grid	0.32	0.27
SS Ultra Low-E/Argon with Grid	0.29	0.20
DS Ultra Low-E/Argon with Grid	0.29	0.20
DS Low-E/Argon Glass with Grid	0.36	0.19
SS Turtle Code Low-E No Grid	0.36	0.19
DS Turtle Code Low-E No Grid	0.33	0.19
SS Turtle Code Low-E/Argon No Grid	0.33	0.18
DS Turtle Code Low-E/Argon No Grid	0.49	0.50
SS Clear Glass with SDL	0.49	0.49
DS Clear Glass with SDL	0.36	0.24
SS Low-E Glass with SDL	0.35	0.24
DS Low-E Glass with SDL	0.32	0.24
SS Low-E/Argon Glass with SDL	0.29	0.20
SS Ultra Low-E/Argon with SDL	0.29	0.20
DS Ultra Low-E/Argon with SDL	0.36	0.17
DS Low-E/Argon Glass with SDL	0.36	0.17
SS Turtle Code Low-E with SDL	0.33	0.17
DS Turtle Code Low-E with SDL	0.33	0.17

# SERIES 130 SINGLE HUNG

SERIES	130 SH
VINYL WALL THICKNESS	0.060"
GLASS THICKNESS	0.750" (19.05MM)
JAMB THICKNESS	3"
FRAME WIDTH	2.412"
NAILING FIN LENGTH	1.365"
NAIL FIN SETBACK	1.9375"
"J" CHANNEL DEPTH	.625" (15.88MM) (N/A ON 160)
EGRESS WIDTH	(WW) - 4.75"
EGRESS HEIGHT (WITH SASH)	(WH/2) - 3"
SCREEN WIDTH	(WW) - 3.6875"
SCREEN HEIGHT	(WH/2) - 1.8125"
<b>OPTIONS GLASS:</b>	
CLEAR (STANDARD)	•
LOW-E ARGON	•
ULTRA LOW-E WITH ARGON	•
OBSCURE	•
TEMPERED	•
DOUBLE STRENGTH	•
<b>OPTIONS GAS:</b>	
ARGON	•
<b>AVAILABLE SPECIAL SHAPES:</b>	
FULL ROUNDS	QUARTER ROUNDS
HALF ROUNDS	ELLIPTICALS
OCTAGONS	PENTAGONS
TRAPEZOIDS	TRIANGLES
HALF EYEBROWS	EYEBROWS
COLONIAL ARCHES	COLONIAL FLANKERS
OVALS	COLONIAL ARCH FLANKERS
<b>COLOR:</b>	
WHITE	•
ALMOND	•
CLAY	•

(WW) = WINDOW WIDTH  
 (WH) = WINDOW HEIGHT

## Series 130 SH vertical diagram

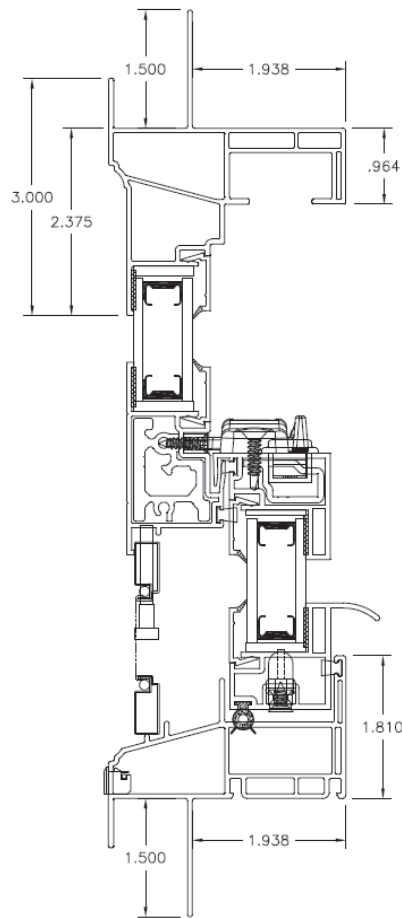

## Series 130 SH horizontal diagram

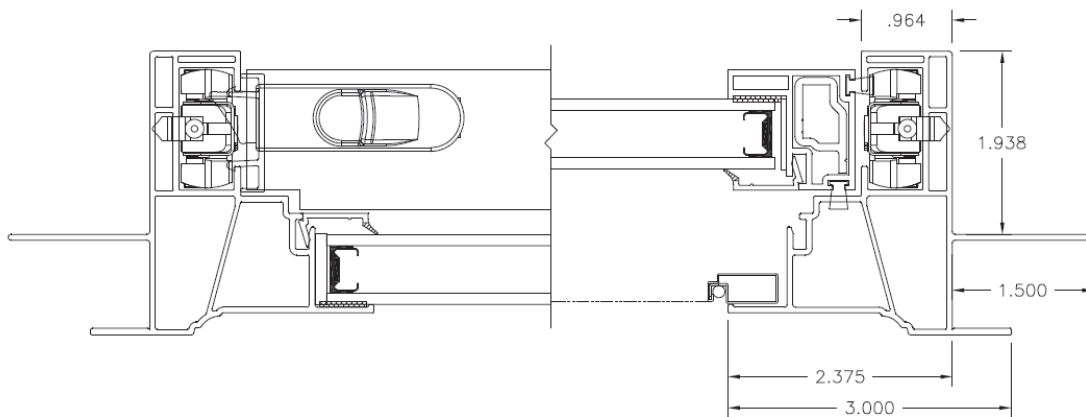



# SERIES 130 SINGLE HUNG

**Series 130 SH  
vertical diagram  
Box**

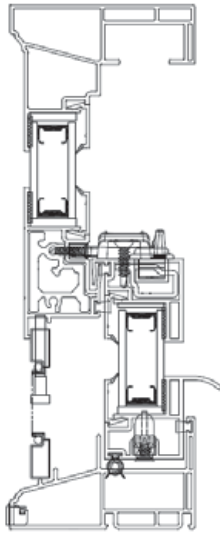

**Series 130 SH  
vertical diagram  
Fin & Flange**

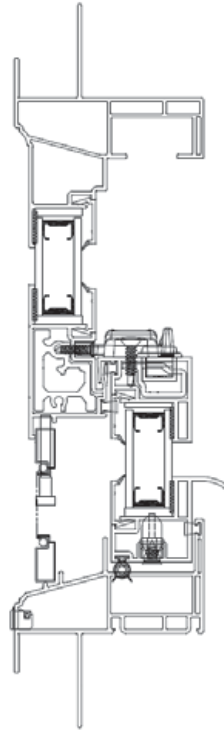

**Series 130 SH  
vertical diagram  
Fin Only**

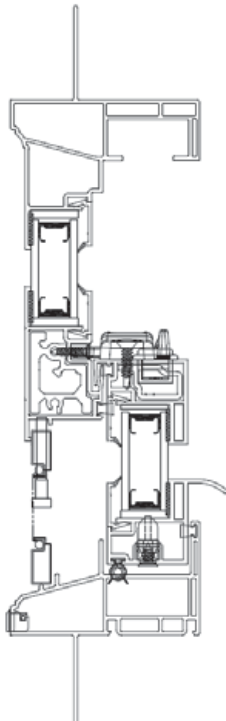

**Series 130 SH  
vertical diagram  
Flange Only**

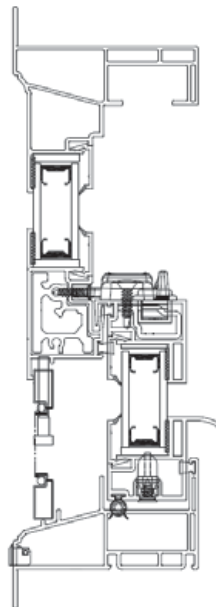

## Mulled Units:

Factory mulling of twins, triples and special shapes provides easier installation without extra labor or material costs.

Series 130

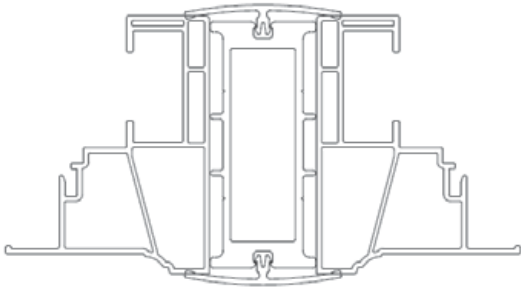

## Recommended Rough Opening for Wood Frame Openings:

Width = Window Width (WW) + 1/2"

Height = Window Height (WH) + 1/2"

## Wood-Jamb Extension:

The interior wood-jamb extension is available in pre primed or stainable version for your convenience and ease of installation for a frame thickness of either 4 9/16" or 6 9/16".

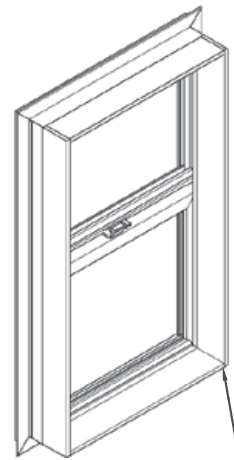

WOOD EXTENSION 3" X 5/8"  
OVERALL WALL THICKNESS = 4 9/16"

# SERIES 130 SINGLE HUNG





































































## Series 130 Single Hung Size Chart

SERIES 130 SINGLE HUNG

\*Meets egress of: Clear operable area of  $\geq 5.7$  sq. ft.

Clear operable width of  $\geq 20"$

Clear operable height of  $\geq 24"$

ROUGH OPENING	24"	28"	30"	32"	36"	40"	42"	44"	48"
EXACT SIZE	23.5"	27.5"	29.5"	31.5"	35.5"	39.5"	41.5"	43.5"	47.5"
EGRESS WIDTH	18.75"	22.75"	24.75"	26.75"	30.75"	34.75"	36.75"	38.75"	42.75"
36"									
44"									
48"									
52"									
60"									
62"									
66"									
72"									

# SERIES 130 SINGLE HUNG























## Series 130 Single Hung Commodity Size Charts

### SERIES 130 SINGLE HUNG

\*Meets egress of: Clear operable area of  $\geq 5.7$  sq. ft.

Clear operable width of  $\geq 20"$

Clear operable height of  $\geq 24"$

MASONRY OPENING	19 7/8"	27 1/4"	37 3/4"	53 3/4"		
TIP TO TIP	19 3/8"	26 3/4"	37 1/4"	53 3/8"		
EXACT SIZE	18 1/8"	25 1/2"	36"	52 1/8"		
26" 38 3/8" 50 5/8" 63" 72" 76 3/4"	26" 1/4" 38 5/8" 50 7/8" 63 1/4" 72 1/4" 77"	25" 37 3/8" 49 5/8" 62" 71" 75 3/4"	 12	 1/32	 22	 32
 13	 1/33	 23	 33			
 14	 1/34	 24	 34			
 15	 1/35	 25	 35			
 16	 1/36	 26	 36			
 1 x 76 3/4	 1/3 x 76 3/4	 2 x 76 3/4				

### SERIES 130 SINGLE HUNG

Commodity Size	Masonry Opening Size	Tip to Tip Size	Exact Size
12	19 7/8 x 26	19 3/8 x 26 1/4	18 1/8 x 25
13	19 7/8 x 38 3/8	19 3/8 x 38 5/8	18 1/8 x 37 3/8
14	19 7/8 x 50 5/8	19 3/8 x 50 7/8	18 1/8 x 49 5/8
15	19 7/8 x 63	19 3/8 x 63 1/4	18 1/8 x 62
16	19 7/8 x 72	19 3/8 x 72 1/4	18 1/8 x 71
1 x 76 3/4	19 7/8 x 76 3/4	19 3/8 x 77	18 1/8 x 75 3/4
1/32	27 1/4 x 26	26 3/4 x 26 1/4	25 1/2 x 25
1/33	27 1/4 x 38 3/8	26 3/4 x 38 5/8	25 1/2 x 37 3/8
1/34	27 1/4 x 50 5/8	26 3/4 x 50 7/8	25 1/2 x 49 5/8
1/35	27 1/4 x 63	26 3/4 x 63 1/4	25 1/2 x 62
1/36	27 1/4 x 72	26 3/4 x 72 1/4	25 1/2 x 71
1/3 x 76 3/4	27 1/4 x 76 3/4	26 3/4 x 77	25 1/2 x 75 3/4

Commodity Size	Masonry Opening Size	Tip to Tip Size	Exact Size
22	37 3/4 x 26	37 1/4 x 26 1/4	36 x 25
23	37 3/4 x 38 3/8	37 1/4 x 38 5/8	36 x 37 3/8
24	37 3/4 x 50 5/8	37 1/4 x 50 7/8	36 x 49 5/8
25	37 3/4 x 63	37 1/4 x 63 1/4	36 x 62
26	37 3/4 x 72	37 1/4 x 72 1/4	36 x 71
2 x 76 3/4	37 3/4 x 76 3/4	37 1/4 x 77	36 x 75 3/4
32	53 3/4 x 26	53 3/8 x 26 1/4	52 1/8 x 25
33	53 3/4 x 38 3/8	53 3/8 x 38 5/8	52 1/8 x 37 3/8
34	53 3/4 x 50 5/8	53 3/8 x 50 7/8	52 1/8 x 49 5/8
35	53 3/4 x 63	53 3/8 x 63 1/4	52 1/8 x 62
36	53 3/4 x 72	53 3/8 x 72 1/4	52 1/8 x 71

# SERIES 130 SINGLE HUNG

## Series 130 Single Hung Egress Charts

### SERIES 130 SINGLE HUNG EGRESS SQUARE FOOTAGE

NOM. SIZE	EGRESS TOTAL SQUARE FEET (WITH SASH)
2030	1.92
2038	2.44
2040	2.70
2044	2.96
2050	3.48
2052	3.61
2056	3.87
2060	4.26
2430	2.33
2438	2.96
2440	3.28
2444	3.59
2450	4.23
2452	4.38
2456	4.70
2460	5.17
2630	2.54
2638	3.22
2640	3.57
2644	3.91
2650	4.60
2652	4.77
2656	5.11
2660	5.63

NOM. SIZE	EGRESS TOTAL SQUARE FEET (WITH SASH)
2830	2.74
2838	3.48
2840	3.85
2844	4.23
2850	4.97
2852	5.15
2856	5.53
2860	6.08
3030	3.15
3038	4.00
3040	4.43
3044	4.86
3050	5.71
3052	5.93
3056	6.35
3060	6.99
3430	3.56
3438	4.52
3440	5.01
3444	5.49
3450	6.46
3452	6.70
3456	7.18
3460	7.90

NOM. SIZE	EGRESS TOTAL SQUARE FEET (WITH SASH)
3630	3.76
3638	4.79
3640	5.30
3644	5.81
3650	6.83
3652	7.08
3656	7.59
3660	8.36
3830	3.97
3838	5.05
3840	5.58
3844	6.12
3850	7.20
3852	7.47
3856	8.01
3860	8.81
4030	4.38
4038	5.57
4040	6.16
4044	6.75
4050	7.94
4052	8.24
4056	8.83
4060	9.72

## 130 Single Hung Commodity Egress Chart

Commodity Size	Tip to Tip Size	Exact Size	With Sash	Sq. Feet
12	19 1/4 x 26 1/4	18 1/8 x 25	13 3/8 x 9 4/8	0.88
13	19 1/4 x 38 5/8	18 1/8 x 37 3/8	13 3/8 x 15 6/8	1.46
14	19 1/4 x 50 7/8	18 1/8 x 49 5/8	13 3/8 x 21 7/8	2.03
15	19 1/4 x 63 1/4	18 1/8 x 62	13 3/8 x 28	2.60
16	19 1/4 x 72 1/4	18 1/8 x 71	13 3/8 x 32 4/8	3.02
1 x 76 3/4	19 1/4 x 77	18 1/8 x 75 3/4	13 3/8 x 34 7/8	3.24
1/32	26 3/4 x 26 1/4	25 1/2 x 25	20 3/4 x 9 4/8	1.37
1/33	26 3/4 x 38 5/8	25 1/2 x 37 3/8	20 3/4 x 15 6/8	2.26
1/34	26 3/4 x 50 7/8	25 1/2 x 49 5/8	20 3/4 x 21 7/8	3.14
1/35	26 3/4 x 63 1/4	25 1/2 x 62	20 3/4 x 28	4.03
1/36	26 3/4 x 72 1/4	25 1/2 x 71	20 3/4 x 32 4/8	4.68
1/3 x 76 3/4	26 3/4 x 77	25 1/2 x 75 3/4	20 3/4 x 34 7/8	5.03
22	37 1/4 x 26 1/4	36 x 25	31 1/4 x 9 4/8	2.06
23	37 1/4 x 38 5/8	36 x 37 3/8	31 1/4 x 15 6/8	3.40
24	37 1/4 x 50 7/8	36 x 49 5/8	31 1/4 x 21 7/8	4.73
39 3/8 x 58 1/8	39 3/8 x 58 1/8	38 1/8 x 56 7/8	33 3/8 x 25 4/8	5.90
25	37 1/4 x 63 1/4	36 x 62	31 1/4 x 28	6.08
26	37 1/4 x 72 1/4	36 x 71	31 1/4 x 32 4/8	7.05
2 x 76 3/4	37 1/4 x 77	36 x 75 3/4	31 1/4 x 34 7/8	7.57
32	53 3/8 x 26 1/4	52 1/8 x 25	47 3/8 x 9 4/8	3.13
33	53 3/8 x 38 5/8	52 1/8 x 37 3/8	47 3/8 x 15 6/8	5.16
34	53 3/8 x 50 7/8	52 1/8 x 49 5/8	47 3/8 x 21 7/8	7.18
35	53 3/8 x 63 1/4	52 1/8 x 62	47 3/8 x 28	9.21
36	53 3/8 x 72 1/4	52 1/8 x 71	47 3/8 x 32 4/8	10.69

# SERIES 150/160 SINGLE HUNG

## Features:

- Cam Locks are standard. Double Locks are featured on all windows measuring more than 27 1/4" in width.
- Block & tackle balances provide quiet, easy operation.
- Integrated tilt latches permit easy tilt in and cleaning.
- Sloped sill for easy water run-off.
- Pre-punched nailing fin allows for faster installation.
- Sashes are available in equal lite, Cottage and Oriol styles.
- Integrated J-channel assists in the installation of vinyl siding.
- White is standard.
- Series 160 available without J-channel.
- DP Ratings:  
 DP 50 (window size tested 36" x 74")  
 DP 35 (window size tested 36" x 96")  
 DP 25 (window size tested 48" x 96")

## Custom Options:

- Low-E Glass and Argon Gas
- Ultra Low-E Argon.
- 3/4" or 5/8" flat grid and 5/8" or 1" contoured grid.
- Factory mulling of twins, triples and architectural shapes.
- Almond and clay are available.
- Wood jamb extensions (pre-primed or stainable 4 9/16" and 6 9/16").
- Window Opening Control Device (WOCD) for fall prevention (field applied).
- Continuous Head and Sill.

## Materials:

- Frame and sash are maintenance free, color stabilized solid vinyl (PVC).
- Lift rail, lock rail, and the meeting rail contain aluminum rebar for added strength. Windows more than 60" in height also have rebar in the stiles.
- The screen is comprised of rolled form aluminum frame and fiberglass mesh.
- Glazing method: Glazing tape.

## Structural Performance

SERIES/MODEL	TEST SIZE	AIR (cfm/ft <sup>2</sup> )	WATER (psf)	UNIFORM LOAD	DESIGN PRESSURE
150/160 SH/DW	36 X 74	0.27	7.50	75.00	H-R50 36X74
150/160 SH/DW	48 X 78	0.27	7.50	37.50	H-R25 48X78
150/160 SHTW	72 X 72	0.15	6.75	60.00	H-R40 72X72
150/160 TRHP	108 X 74	0.15	7.50	75.00	H-R50 108X74
150/160 TR	108 X 74	0.15	6.00	45.00	H-R30 108X74
150/160 PW/HR/FR/OC/SS	72 X 72	0.01	7.50	75.00	F-R50 72x72

## Thermal Performance

GLASS/GRID	U-Value	SHGC
SS Clear Glass No Grid	0.49	0.62
DS Clear Glass No Grid	0.49	0.61
SS Low-E Glass No Grid	0.35	0.29
DS Low-E Glass No Grid	0.35	0.29
SS Low-E/Argon Glass No Grid	0.32	0.29
DS Low-E/Argon Glass No Grid	0.32	0.29
SS Ultra Low-E/Argon No Grid	0.30	0.22
DS Ultra Low-E/Argon No Grid	0.30	0.22
SS Clear Glass with Grid	0.49	0.56
DS Clear Glass with Grid	0.49	0.55
SS Low-E Glass with Grid	0.35	0.27
DS Low-E Glass with Grid	0.35	0.26

GLASS/GRID	U-Value	SHGC
SS Low-E/Argon Glass with Grid	0.32	0.26
DS Low-E/Argon Glass with Grid	0.32	0.26
SS Ultra Low-E/Argon with Grid	0.30	0.20
DS Ultra Low-E/Argon with Grid	0.30	0.20
SS Clear Glass with SDL	0.49	0.50
DS Clear Glass with SDL	0.51	0.49
SS Low-E Glass with SDL	0.36	0.27
DS Low-E Glass with SDL	0.39	0.27
SS Low-E/Argon Glass with SDL	0.32	0.26
DS Low-E/Argon Glass with SDL	0.34	0.24
SS Ultra Low-E/Argon Glass with SDL	0.30	0.20
DS Ultra Low-E/Argon Glass with SDL	0.32	0.20

# SERIES 150/160 SINGLE HUNG

SERIES	150/160 SH
VINYL WALL THICKNESS	0.065" (1.65MM)
GLASS THICKNESS	0.750" (19.05MM)
JAMB THICKNESS	3.277" (83.24MM)
FRAME WIDTH	2.412" (61.26MM)
NAILING FIN LENGTH	1.365" (34.67MM)
NAIL FIN SETBACK	1.537" (39.04MM)
"J" CHANNEL DEPTH	.625" (15.88MM)
EGRESS WIDTH	(WW) - 4 13/16"
EGRESS HEIGHT (WITH SASH)	(WH/2) - 3 15/16"
EGRESS HEIGHT (WITHOUT SASH)	(WH/2) - 3 1/8"
TOP SASH DAYLIGHT OPENING WIDTH	(WW) - 5 1/8"
BOTTOM SASH DAYLIGHT OPENING WIDTH	(WW) - 5 1/2"
DAYLIGHT OPENING HEIGHT	(WH/2) - 3 7/16"
SCREEN WIDTH	(WW) - 4 3/8"
SCREEN HEIGHT	(WH/2) - 1 1/4"
<b>OPTIONS GLASS:</b>	
CLEAR (STANDARD)	•
LOW-E ARGON	•
ULTRA LOW-E WITH ARGON	•
OBSCURE	•
TEMPERED	•
DOUBLE STRENGTH	•
<b>OPTIONS GAS:</b>	
ARGON	•
<b>AVAILABLE SPECIAL SHAPES:</b>	
FULL ROUNDS	QUARTER ROUNDS
HALF ROUNDS	ELLIPTICALS
OCTAGONS	PENTAGONS
TRAPEZOIDS	TRIANGLES
HALF EYEBROWS	EYEBROWS
COLONIAL ARCHES	COLONIAL FLANKERS
OVALS	COLONIAL ARCH FLANKERS
OPERABLE EYEBROWS	OPERABLE HALF EYEBROWS
<b>COLOR:</b>	
WHITE	•
ALMOND	•
CLAY	•

(WW) = WINDOW WIDTH  
(WH) = WINDOW HEIGHT

# SERIES 150/160 SINGLE HUNG

**Series 150 vertical diagram**

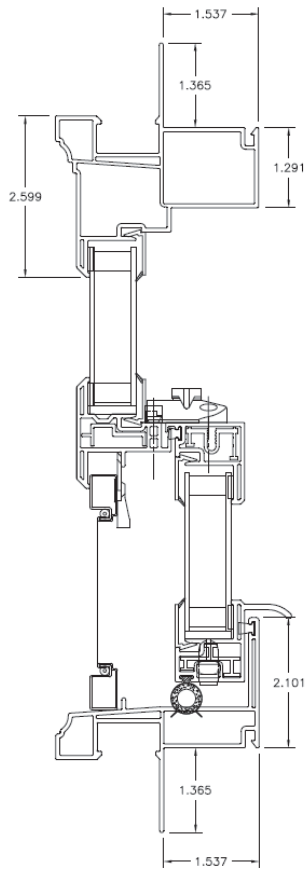

**Series 160 vertical diagram**

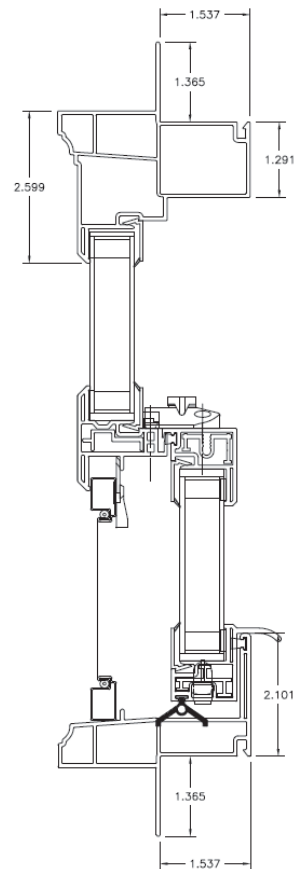

**Series 150 horizontal diagram**

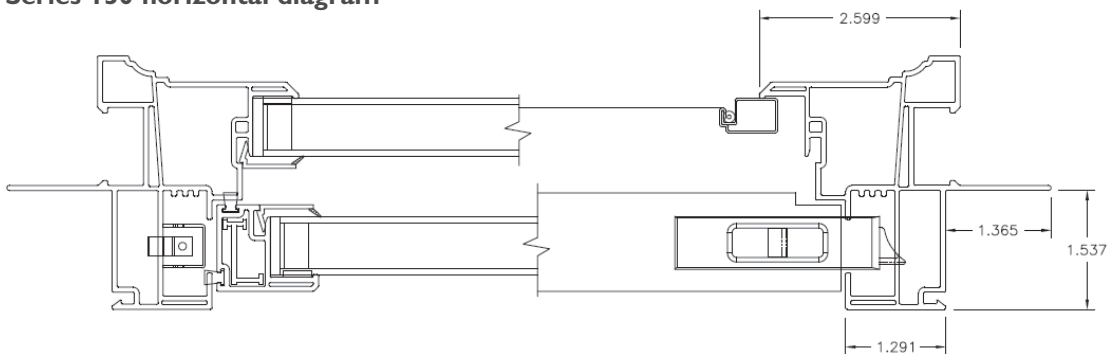

**Series 160 horizontal diagram**

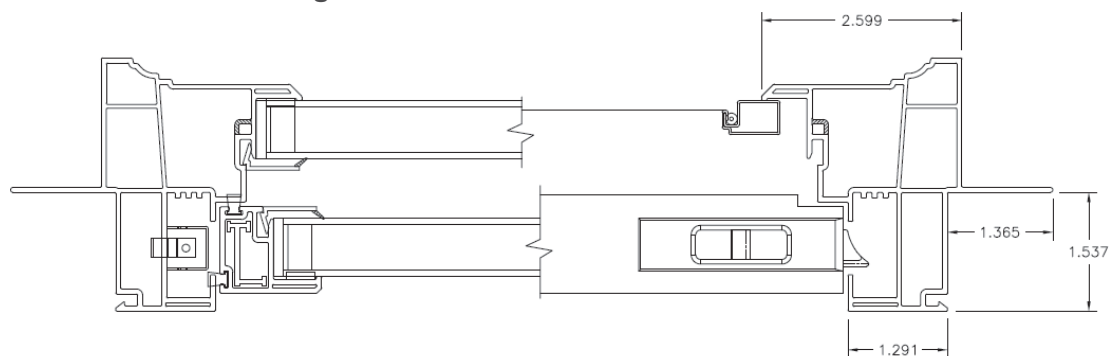



## Mulled Units:

Factory mulling of twins, triples and special shapes provides easier installation without extra labor or material costs.

Reinforcement is available for added strength in factory mulled units.

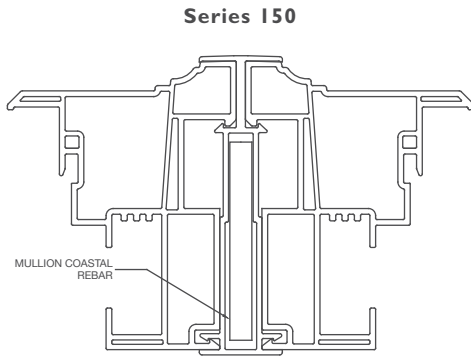

### Recommended Rough Opening:

Width = Window Width (WW) – 1/2"

Height = Window Height (WH) – 1/2"

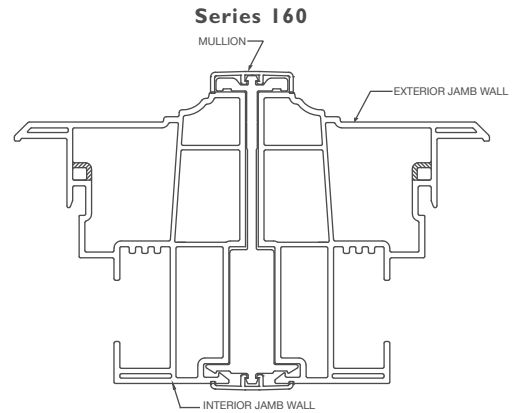

### Recommended Rough Opening:

Width = Window Width (WW) – 1/2"

Height = Window Height (WH) – 1/2"

## Wood-Jamb Extension:

The interior wood-jamb extension is available in pre primed or stainable version for your convenience and ease of installation for a frame thickness of either 4 9/16" or 6 9/16".

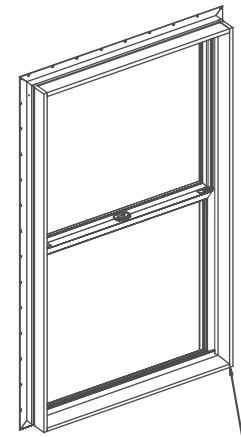

WOOD EXTENSION 3" X 5/8"  
OVERALL WALL THICKNESS = 4 9/16"

# SERIES 150/160 SINGLE HUNG

## Series 150/160 Single Hung Size Chart

SERIES 150/160 SINGLE HUNG

\*Meets egress of: Clear operable area of  $\geq 5.7$  sq. ft.

Clear operable width of  $\geq 20"$

Clear operable height of  $\geq 24"$

ROUGH OPENING	20"	24"	28"	30"	32"	36"	38"	40"	44"	48"
EXACT SIZE	19.5"	23.5"	27.5"	29.5"	31.5"	35.5"	37.5"	39.5"	43.5"	47.5"
EGRESS WIDTH	14.6875"	18.6875"	22.6875"	24.6875"	26.6875"	30.6875"	32.6875"	34.6875"	38.6875"	42.6875"
HEIGHT										
36"	1830	2030	2430	2630	2830	3030	3230	3430	3830	
38"	1832	2032	2432	2632	2832	3032	3232	3432	3832	
44"	1838	2038	2438	2638	2838	3038	3238	3438	3838	
46"	18310	20310	24310	26310	28310	30310	32310	34310	38310	
48"	1840	2040	2440	2640	2840	3040	3240	3440	3840	
50"	1842	2042	2442	2642	2842	3042	3242	3442	3842	
52"	1844	2044	2444	2644	2844	3044	3244	3444	3844	
54"	1846	2046	2446	2646	2846	3046	3246	3446	3846	
60"	1850	2050	2450	2650	2850	3050	3250*	3450*	3850*	4050*
62"	1852	2052	2452	2652	2852	3052*	3252*	3452*	3852*	4052*
66"	1856	2056	2456	2656	2856	3056*	3256*	3456*	3856*	4056*
72"	1860	2060	2460	2660	2860*	3060*	3260*	3460*	3860*	4060*
74"	1862	2062	2462	2662	2862*	3062*	3262*	3462*	3862*	4062*
84"	1870	2070	2470*	2670*	2870*	3070*	3270*	3470*	3870	4070

# SERIES 150/160 SINGLE HUNG

## Series 150/160 Single Hung Egress Chart

### SERIES 150/160 SINGLE HUNG DAYLIGHT OPENING AND EGRESS SQUARE FOOTAGE

NOM. SIZE	WINDOW TOTAL DAYLIGHT OPENING SQUARE FEET	EGRESS TOTAL SQUARE FEET (WITH SASH)	NOM. SIZE	WINDOW TOTAL DAYLIGHT OPENING SQUARE FEET	EGRESS TOTAL SQUARE FEET (WITH SASH)
1830	2.82	1.4	3030	6.00	2.9
1832	3.02	1.5	3032	6.42	3.2
1838	3.61	1.8	3038	7.68	3.8
18310	3.81	1.9	30310	8.10	4.0
1840	4.00	2.0	3040	8.52	4.2
1842	4.20	2.1	3042	8.94	4.4
1844	4.40	2.2	3044	9.35	4.7
1846	4.59	2.3	3046	9.77	4.9
1850	5.18	2.6	3050	11.03	5.5
1852	5.38	2.7	3052	11.45	5.7
1856	5.78	2.9	3056	12.29	6.1
1860	6.37	3.2	3060	13.55	6.8
1862	6.56	3.4	3062	13.97	7.0
1870	7.55	3.9	3070	16.06	8.0
2030	3.62	1.8	3230	6.40	2.9
2032	3.87	1.9	3232	6.85	3.2
2038	4.63	2.3	3238	8.19	3.8
20310	4.88	2.4	32310	8.63	4.0
2040	5.13	2.6	3240	9.08	4.2
2042	5.38	2.7	3242	9.53	4.4
2044	5.64	2.8	3244	9.97	5.0
2046	5.89	3.0	3246	10.42	5.2
2050	6.65	3.4	3250	11.76	5.9
2052	6.90	3.5	3252	12.21	6.0
2056	7.40	3.7	3256	13.10	6.5
2060	8.16	4.1	3260	14.45	7.2
2062	8.41	4.3	3262	14.89	7.5
2070	9.68	4.9	3270	17.13	8.6
2430	4.41	2.2	3430	6.80	3.3
2432	4.72	2.3	3432	7.27	3.6
2438	5.64	2.8	3438	8.70	4.3
24310	5.95	3.0	34310	9.17	4.5
2440	6.26	3.1	3440	9.64	4.8
2442	6.57	3.3	3442	10.12	5.0
2444	6.88	3.4	3444	10.59	5.3
2446	7.18	3.6	3446	11.07	5.5
2450	8.11	4.0	3450	12.49	6.2
2452	8.42	4.2	3452	12.97	6.5
2456	9.03	4.5	3456	13.92	6.9
2460	9.96	5.0	3460	15.34	7.7
2462	10.27	5.2	3462	15.82	7.9
2470	11.81	6.0	3470	18.19	9.1
2630	4.81	2.4	3830	7.59	3.7
2632	5.14	2.5	3832	8.12	4.0
2638	6.15	3.1	3838	9.71	4.8
26310	6.49	3.2	38310	10.24	5.0
2640	6.82	3.4	3840	10.77	5.3
2642	7.16	3.6	3842	11.30	5.6
2644	7.50	3.7	3844	11.83	5.9
2646	7.83	3.9	3846	12.36	6.1
2650	8.84	4.4	3850	13.96	6.9
2652	9.18	4.6	3852	14.49	7.2
2656	9.85	4.9	3856	15.55	7.7
2660	10.85	5.5	3860	17.14	8.6
2662	11.19	5.6	3862	17.67	8.8
2670	12.87	6.5	3870	20.32	10.2
2830	5.21	2.6	4050	15.42	7.7
2832	5.57	2.8	4052	16.00	8.0
2838	6.66	3.3	4056	17.18	8.5
28310	7.02	3.5	4060	18.93	9.4
2840	7.39	3.7	4062	19.52	9.7
2842	7.75	3.9	4070	22.45	11.2
2844	8.12	4.0			
2846	8.48	4.2			
2850	9.57	4.8			
2852	9.93	5.0			
2856	10.66	5.3			
2860	11.75	5.9			
2862	12.12	6.1			
2870	13.93	7.0			

# SERIES 450/460 DOUBLE HUNG

## Features:

- Brick mould exterior.
- Maintenance-free, premium vinyl construction.
- Fusion-welded frame and sash.
- Integrated J-channel and prepunched nailing fin.
- 3/4" insulated glass.
- Sloped sill for easy water run-off.
- Double sash locks standard at 27 1/4" and wider.
- Continuous head and sill for twins and triples.
- Block & tackle balance system.
- Extruded Half screen standard.
- White is standard.
- Series 460 available without "J" channel.
- DP Ratings:  
R50 (window size tested 36" x 74")  
R30 (window size tested 48" x 78")

## Custom Options:

- Low-E Glass and Argon Gas
- Ultra Low-E Argon.
- 5/8" or 1" contoured, 5/8" or 3/4" flat grid or 1 1/8" Simulated Divided Lite.
- Factory mulling of twins, triples and architectural shapes.
- Wood jamb extensions (pre-primed or stainable 4 9/16" and 6 9/16").
- Custom sizes available.
- Almond and Clay are available.
- 3 1/4" Flat Casing with Bull Nose.
- Window Opening Control Device (WOCD) for fall prevention (factory applied).
- Extruded Full Screen.

## Materials:

- Frame and sash are maintenance free, color stabilized solid vinyl (PVC).
- Keeper rail, lock rail and bottom lift rail contain an aluminum rebar for added strength.
- The screen is comprised of a roll form aluminum frame and fiberglass mesh.
- Glazing method: Glazing tape.

## Structural Performance

SERIES/MODEL	TEST SIZE	AIR (cfm/ft <sup>2</sup> )	WATER (psf)	UNIFORM LOAD	DESIGN PRESSURE
450/460 DH	36 x 74	0.26	5.43	52.63	H-R35 36x74
450/460 DH	48 x 78	0.26	5.43	30.08	H-R20 48x78
450/460 DHTR (cont. head & sill)	108 x 74	0.16	7.52	52.67	H-R25 108x74
455/465 DH HP	36 x 74	0.26	7.52	75.19	H-R50 36x74
455/465 DHTRCHS	108 x 74	0.16	7.52	75.19	H-R50 108x74
450/460 and 455/465 PW/HR/FR/OC/SS	50 x 86	0.01	7.52	75.24	F-R50 50x86

## Thermal Performance

GLASS/GRID	U-Value	SHGC
SS Clear Glass No Grid	0.47	0.58
DS Clear Glass No Grid	0.47	0.57
SS Low-E Glass No Grid	0.35	0.28
DS Low-E Glass No Grid	0.35	0.28
SS Low-E/Argon Glass No Grid	0.32	0.27
DS Low-E/Argon Glass No Grid	0.32	0.27
SS Ultra Low-E/Argon No Grid	0.30	0.20
DS Ultra Low-E/Argon No Grid	0.30	0.20
SS Clear Glass with Grid	0.47	0.52
DS Clear Glass with Grid	0.47	0.51
SS Low-E Glass with Grid	0.35	0.25
DS Low-E Glass with Grid	0.35	0.25

GLASS/GRID	U-Value	SHGC
SS Low-E/Argon Glass with Grid	0.32	0.25
DS Low-E/Argon Glass with Grid	0.32	0.25
SS Ultra Low-E/Argon with Grid	0.30	0.18
DS Ultra Low-E/Argon with Grid	0.30	0.19
SS Clear Glass with SDL	0.48	0.46
DS Clear Glass with SDL	0.49	0.45
SS Low-E Glass with SDL	0.35	0.25
DS Low-E Glass with SDL	0.36	0.25
SS Low-E/Argon Glass with SDL	0.31	0.25
DS Low-E/Argon Glass with SDL	0.32	0.25
SS Ultra Low-E/Argon Glass with SDL	0.30	0.18
DS Ultra Low-E/Argon Glass with SDL	0.30	0.19

# SERIES 450/460 DOUBLE HUNG

SERIES	450/460 DH
VINYL WALL THICKNESS: FRAME/SASH	SASH = 0.070" (1.78MM) FRAME = 0.065" (1.65MM)
GLASS THICKNESS	0.750" (19.05MM)
JAMB THICKNESS	3.868" (98.25MM)
FRAME WIDTH	2.563" (65.10MM)
NAILING FIN LENGTH	1.365" (34.67MM)
NAIL FIN SETBACK	2.185" (55.50MM)
"J" CHANNEL DEPTH	.750" (19.05MM)
EGRESS WIDTH	(WW) - 4 3/4"
EGRESS HEIGHT (WITH SASH)	(WH/2) - 5 9/16"
EGRESS HEIGHT (WITHOUT SASH)	(WH/2) - 2 1/2"
SASH DAYLIGHT OPENING WIDTH	(WW) - 6 3/4"
DAYLIGHT OPENING HEIGHT	(WH/2) - 4 1/8"
SCREEN WIDTH	(WW) - 4 7/16"
SCREEN HEIGHT (HALF)	(WH/2)
SCREEN HEIGHT (FULL)	(WH) - 3 5/16"
<b>OPTIONS GLASS:</b>	
CLEAR (STANDARD)	•
LOW-E WITH ARGON	•
ULTRA LOW-E WITH ARGON	•
OBSCURE	•
TEMPERED	•
DOUBLE STRENGTH	•
<b>OPTIONS GAS:</b>	
ARGON	•
<b>AVAILABLE SPECIAL SHAPES:</b>	
FULL ROUNDS	QUARTER ROUNDS
HALF ROUNDS	ELLIPTICALS
OCTAGONS	PENTAGONS
TRAPEZOIDS	TRIANGLES
HALF EYEBROWS	EYEBROWS
COLONIAL ARCHES	COLONIAL FLANKERS
OVALS	COLONIAL ARCH FLANKERS
<b>COLOR:</b>	
WHITE	•
ALMOND	•
CLAY	•

(WW) = WINDOW WIDTH  
(WH) = WINDOW HEIGHT

# SERIES 450/460 DOUBLE HUNG

**Series 450 vertical diagram**

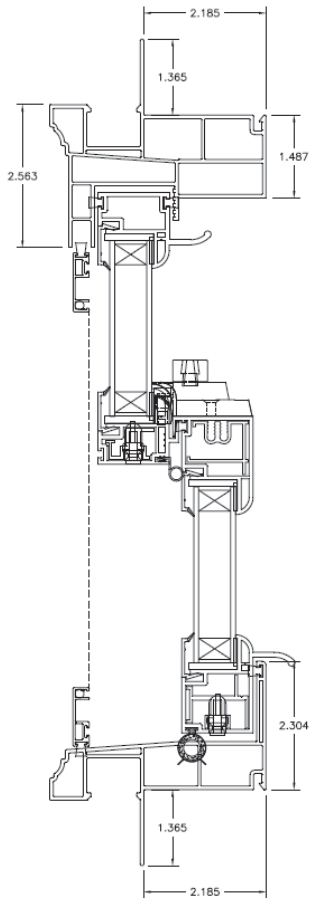

**Series 460 vertical diagram**

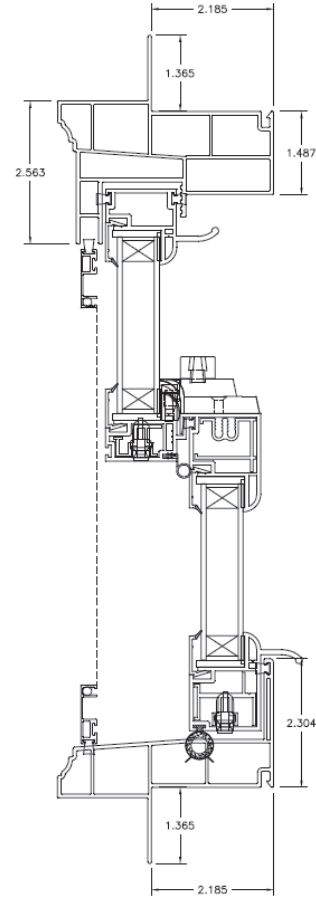

**Series 450 horizontal diagram**

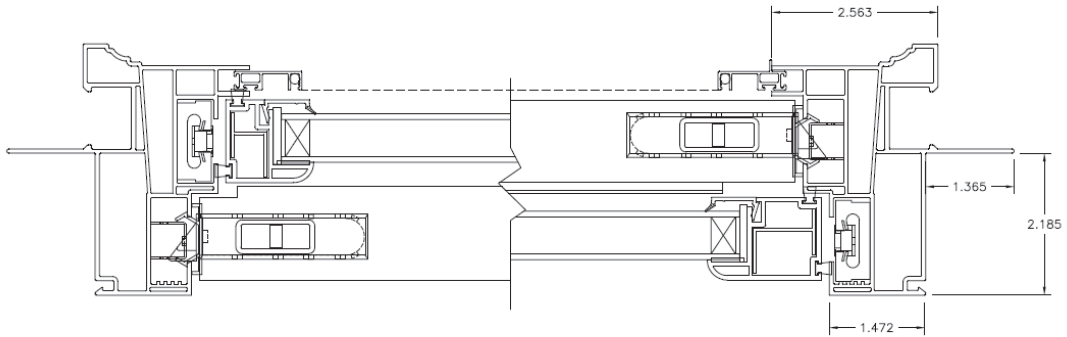

**Series 460 horizontal diagram**

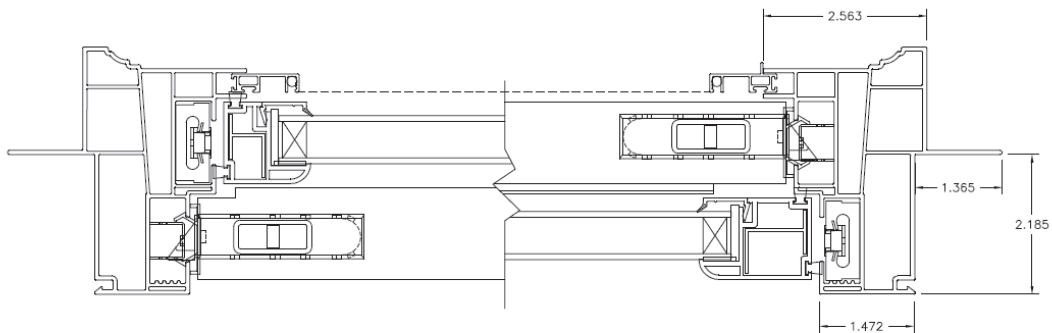

## Mulled Units:

Factory mulling of twins, triples and special shapes provides easier installation without extra labor or material costs.

Steel reinforcement is offered as an option to meet higher wind load requirements.

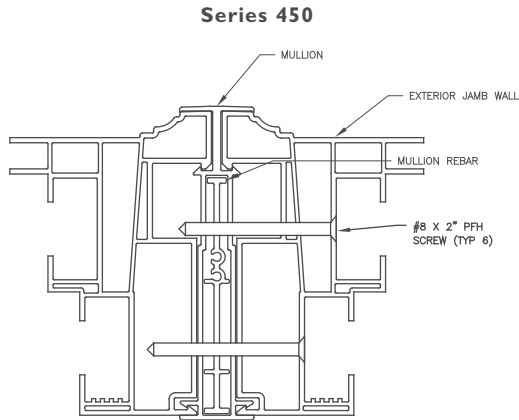

## Recommended Rough Opening:

Width = Window Width (WW) + 1/2"

Height = Window Height (WH) + 1/2"

## Wood-Jamb Extension:

The interior wood-jamb extension is available in pre primed or stainable version for your convenience and ease of installation for a frame thickness of either 4 9/16" or 6 9/16".

**Series 450/460**

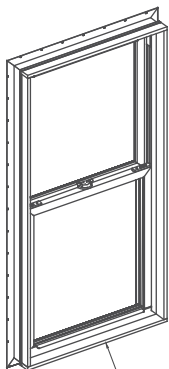

WOOD EXTENSION 2 3/8" X 5/8"  
OVERALL WALL THICKNESS = 4 9/16"

**Series 450/460 Twin**

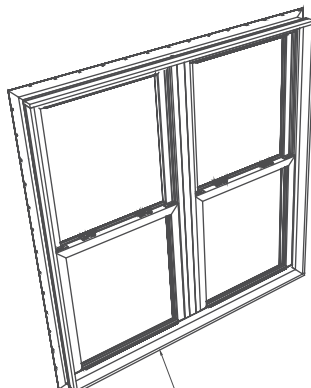

WOOD EXTENSION 2 3/8" X 5/8"  
OVERALL WALL THICKNESS = 4 9/16"

**Series 450/460 Triple**

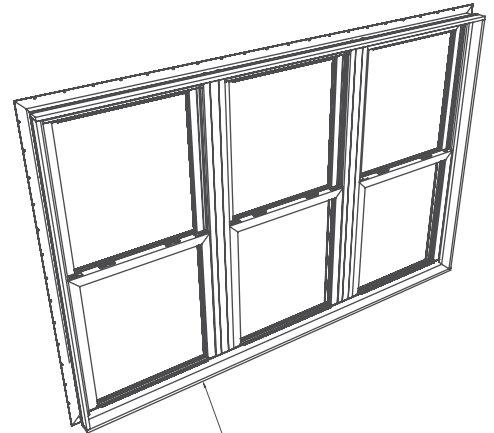

WOOD EXTENSION 2 3/8" X 5/8"  
OVERALL WALL THICKNESS = 4 9/16"

# SERIES 450/460 DOUBLE HUNG

## Series 450/460 Double Hung Size Chart

SERIES 450/460 DOUBLE HUNG

\*Meets egress of: Clear operable area of  $\geq 5.7$  sq. ft.

Clear operable width of  $\geq 20"$

Clear operable height of  $\geq 24"$

ROUGH OPENING	20"	24"	28"	30"	32"	36"	38"	40"	44"	48"
EXACT SIZE	19.5"	23.5"	27.5"	29.5"	31.5"	35.5"	37.5"	39.5"	43.5"	47.5"
EGRESS WIDTH	14.75"	18.75"	22.75"	24.75"	26.75"	30.75"	32.75"	34.75"	38.75"	42.75"
HEIGHT										
36"	1830	2030	2430	2630	2830	3030				
38"	1832	2032	2432	2632	2832	3032				
44"	1838	2038	2438	2638	2838	3038				
46"	18310	20310	24310	26310	28310	30310				
48"	1840	2040	2440	2640	2840	3040	3240			
50"	1842	2042	2442	2642	2842	3042	3242			
52"	1844	2044	2444	2644	2844	3044	3244			
54"	1846	2046	2446	2646	2846	3046	3246			
60"	1850	2050	2450	2650	2850	3050	3250	3450*	3850*	4050*
62"	1852	2052	2452	2652	2852	3052	3252*	3452*	3852*	4052*
66"	1856	2056	2456	2656	2856	3056*	3256*	3456*	3856*	4056*
72"	1860	2060	2460	2660	2860	3060*	3260*	3460*	3860*	4060*
74"	1862	2062	2462	2662	2862*	3062*	3262*	3462*	3862*	4062*



# SERIES 450/460 DOUBLE HUNG

## Series 450/460 Double Hung Egress Chart

### SERIES 450/460 DOUBLE HUNG DAYLIGHT OPENING SIZE CHART

NOM. SIZE	WINDOW TOTAL DAYLIGHT OPENING SQUARE FEET	EGRESS TOTAL SQUARE FEET (WITH SASH)	NOM. SIZE	WINDOW TOTAL DAYLIGHT OPENING SQUARE FEET	EGRESS TOTAL SQUARE FEET (WITH SASH)
1830	2.41	1.3	2830	4.68	2.3
1832	2.59	1.4	2832	5.03	2.5
1838	3.12	1.7	2838	6.06	3.0
18310	3.30	1.8	28310	6.40	3.2
1840	3.48	1.9	2840	6.75	3.4
1842	3.65	2.0	2842	7.09	3.6
1844	3.83	2.1	2844	7.43	3.8
1846	4.01	2.2	2846	7.78	3.9
1850	4.54	2.5	2850	8.81	4.5
1852	4.71	2.6	2852	9.15	4.7
1856	5.07	2.8	2856	9.84	5.1
1860	5.60	3.1	2860	10.87	5.6
1862	5.78	3.2	2862	11.21	5.8
2030	3.17	1.6	3030	5.44	2.6
2032	3.40	1.7	3032	5.84	2.8
2038	4.10	2.1	3038	7.04	3.5
20310	4.33	2.2	30310	7.44	3.7
2040	4.57	2.4	3040	7.84	3.9
2042	4.80	2.5	3042	8.24	4.1
2044	5.03	2.6	3044	8.63	4.3
2046	5.26	2.8	3046	9.03	4.5
2050	5.96	3.2	3050	10.23	5.2
2052	6.19	3.3	3052	10.63	5.4
2056	6.66	3.5	3056	11.43	5.8
2060	7.36	3.9	3060	12.63	6.5
2062	7.59	4.1	3062	13.03	6.7
2430	3.93	1.9	3240	8.38	4.1
2432	4.21	2.1	3242	8.81	4.4
2438	5.08	2.6	3244	9.24	4.6
24310	5.37	2.7	3246	9.66	4.8
2440	5.66	2.9	3250	10.94	5.5
2442	5.94	3.0	3252	11.37	5.7
2444	6.23	3.2	3256	12.23	6.2
2446	6.52	3.4	3260	13.51	6.9
2450	7.38	3.8	3262	13.93	7.1
2452	7.67	4.0	3450	11.66	5.8
2456	8.25	4.3	3452	12.11	6.1
2460	9.11	4.8	3456	13.02	6.6
2462	9.40	4.9	3460	14.38	7.3
2630	4.31	2.1	3462	14.84	7.5
2632	4.62	2.3	3850	13.08	6.5
2638	5.57	2.8	3852	13.59	6.8
26310	5.88	3.0	3856	14.61	7.3
2640	6.20	3.1	3860	16.14	8.1
2642	6.52	3.3	3862	16.65	8.4
2644	6.83	3.5	4050	14.17	7.2
2646	7.15	3.6	4052	14.72	7.5
2650	8.10	4.2	4056	15.83	8.1
2652	8.41	4.3	4060	17.49	9.0
2656	9.04	4.7	4062	18.46	9.3
2660	9.99	5.2			
2662	10.31	5.4			

# HORIZONTAL SLIDERS

SERIES	5700 2SL/3SL	130 2SL/3SL	151/161 2SL	451/461 2SL/3SL
VINYL WALL THICKNESS	0.062"	0.060"	0.065"	0.065"
GLASS THICKNESS	0.750"	0.750"	0.750"	0.750"
JAMB THICKNESS	2.625"	3"	3.277"	3.868"
FRAME WIDTH	1.312"	2.485"	2.416"	2.865"
NAILING FIN LENGTH	1.114"	1.500"	1.365"	1.365"
NAIL FIN SETBACK	1.375"	1.9375"	1.537"	2.185"
"J" CHANNEL DEPTH	N/A	N/A	.625"	.75"
SCREEN WIDTH	(WW/2) - .5625" (WW/3) - .6825" (1/3, 1/3, 1/3) (WW/4) - .6875" (1/4, 1/2, 1/4)	(WW/2) - 3.00" (WW/3) - 2.5625" (1/3, 1/3, 1/3) (WW/4) - 3.125" (1/4, 1/2, 1/4)	(WW/2) - 2 11/16"	(WW/2) - 2 1/8" (1/3, 1/3, 1/3) (WW*.3333) - 1 1/2" (1/4, 1/2, 1/4) (WW/4) - 1 3/8"
SCREEN HEIGHT	(WH) - 1.4375"	(WH) - 3.875"	(WH) - 3 7/8"	(WH) - 4 1/4"
<b>OPTIONS GLASS:</b>				
CLEAR (STANDARD)	•	•	•	•
LOW-E	•	•	•	•
DOUBLE STRENGTH	•	•	•	•
LOW-E WITH ARGON	•	•	•	•
ULTRA LOW-E WITH ARGON	•	•	•	•
TEMPERED	•	•	•	•
OBSCURE	•	•	•	•
<b>OPTIONS GAS:</b>				
ARGON	•	•	•	•
<b>AVAILABLE SPECIAL SHAPES:</b>				
FULL ROUNDS	QUARTER ROUNDS			
HALF ROUNDS	ELLIPTICALS			
OCTAGONS	PENTAGONS			
TRAPEZOIDS	TRIANGLES			
HALF EYEBROWS	EYEBROWS			
COLONIAL ARCHES	COLONIAL FLANKERS			
OVALS	COLONIAL ARCH FLANKERS			
<b>COLOR:</b>				
WHITE	•	•	•	•
ALMOND	•	•	•	•
CLAY	•	•	•	•

(WW) = WINDOW WIDTH  
(WH) = WINDOW HEIGHT

## Structural Performance

SERIES/MODEL	TEST SIZE	AIR (cfm/ft <sub>2</sub> )	WATER (psf)	UNIFORM LOAD	DESIGN PRESSURE
5700 2SL	72 x 72	0.17	3.76		HS-R20 72x72
130 2SL	74 x 63	0.10	7.52		HS-LC40 74x63
151/161 2SL	74 X 48	0.09	4.50	45.00	HS-R30 72x48
451/461 2SL	70 X 49	0.14	3.75	37.50	HS-R25 70x49
5700 3SL	96 x 60	0.06	2.92		HS-R20 96X60
130 3SL	108 X 63	0.08	7.52		HS-R30 108X63
151/161 3SL	108 X 60	0.09	3.00	30.00	HS-R25 108x48

## Features:

- 1-1/4" Nail-fin setback for brick veneer construction and select stucco applications
- Sweep lock helps provide a weather-tight seal and added security
- Versatile half screen\* installs easily from inside
- Multi-chambered vinyl lineals improve thermal performance and enhance sound absorbency
- Fusion-welded frame and sash minimizes water and air infiltration and enhances overall durability
- Metal reinforced meeting rail and sash rail provide added durability and enhanced security
- Limited lifetime warranty provides reassuring peace of mind
- Pre-punched integral nail-fin targets proper nail location for quick, easy installation
- Tandem wheel and axle roller assemblies ensure smooth, easy operation on even the largest sizes
- Multi-cavity vinyl lineals improve thermal performance and enhance sound absorbency
- DP Ratings:  
 R25 (window size tested 72" x 48")  
 R20 (window size tested 72" x 72")  
 R20 (window size tested 96" x 60") (XOX)
- Jamb depth: 2.625"

## Custom Options:

- Low-E Glass.
- Low-E Glass with Argon Gas.
- Ultra Low-E Glass with Argon Gas.
- 5/8" or 3/4" flat, 5/8" or 1" contoured, 5/8" contoured valance grids available.
- Custom sizes available.
- Paintable or stainable wood jamb extensions (4 9/16" and 6 9/16").

## Materials:

- Frame is maintenance free, color stabilized solid vinyl (PVC).
- The screen is comprised of roll formed aluminum frame and fiberglass mesh.
- Glazing method: Glazing tape.

## Mulled Units:

Factory mulling over a slider provides easier installation without extra labor or material costs.

Aluminum reinforcement is standard in factory mulled units.

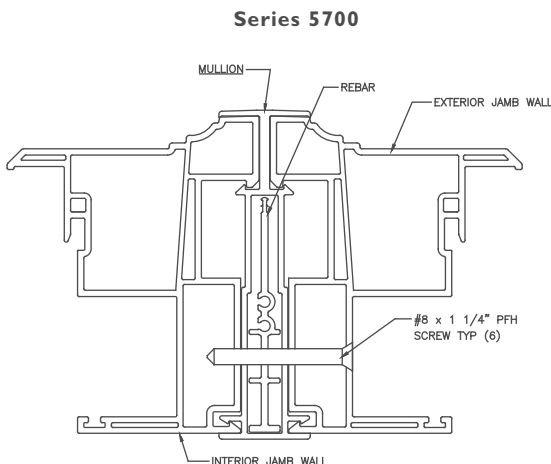

## Recommended Rough Opening:

Width = Window Width (WW) + 1/2"

Height = Window Height (WH) + 1/2"

# SERIES 5700 SLIDERS

**Series 5700 HS vertical diagram**

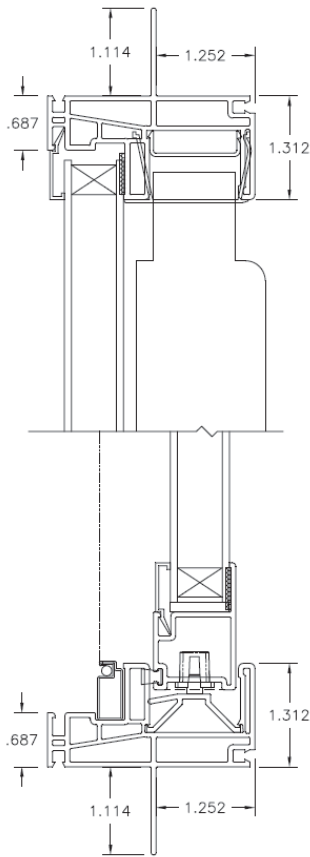

**Series 5700 2-Lite horizontal diagram**

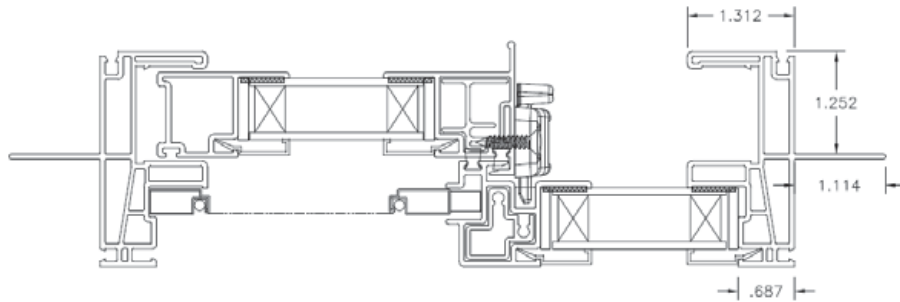

**Series 5700 3-Lite horizontal diagram**

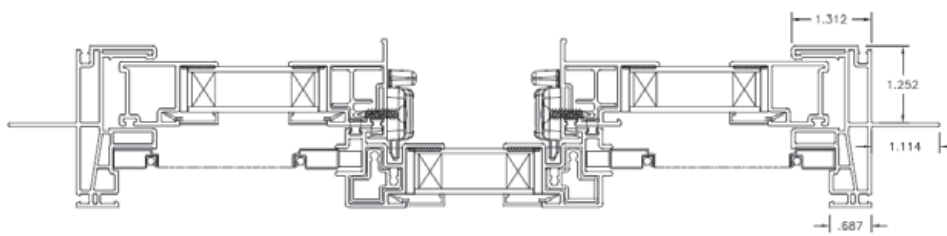

## Features:

- DP 50 RATING (window size tested 74" x 50" for 2-Lite and 108" x 50" for 3-Lite).
- DP 40 Rating (window size tested 74" x 63" 2-Lite).
- DP 30 Rating (window size tested 108" x 63" 3-Lite).
- Step sill design combines water run-off and aesthetic features of a sloped sill with the structural strength and internal drainage system of a pocket sill.
- Tandom rollers ride easily along friction free channel.
- Aluminum half screen comes standard.\*
- Integrated glide rail for easy sash opening and closing.
- Warm-Edge spacer system provides energy saving thermal performance.
- Aluminum reinforcement standard in lock & meeting rails.
- Dual Sweep locks (standard at 27 1/4" and above) help provide a weather-tight seal and added security.
- Dual weather-stripping helps block air and water infiltration, keeping harsh elements outside and energy-saving comfort inside.
- Jamb depth: 3".
- Limited lifetime warranty.
- DP Ratings:  
R50 (window size tested 74" x 50")  
R40 (window size tested 74" x 63")  
R30 (window size tested 108" x 63") (XOX)

## Select from four frame types:

- Front Flange Only
- Nail Fin Only (no J-Channel)
- J-Channel (nail fin & front flange)
- Box Frame (no nail fin & no front flange)

## Custom Options:

- Low-E Glass.
- Low-E Glass with Argon Gas.
- Ultra Low-E Glass with Argon Gas.
- 5/8" or 3/4" flat, 5/8" or 1" contoured and 1 1/8" Simulated Divide Lite (SDL) available
- Non-reflective Low-E Glass and Non-reflective Low-E Glass with Argon Gas.
- Double strength and obscure glass.
- Commodity sizing available.
- Custom sizes available.
- Charcoal Aluminum half screen.

## Materials:

- Frame is maintenance free, color stabilized solid vinyl (PVC).
- The screen is comprised of rolled form aluminum frame and fiberglass mesh.

## Mulled Units:

Series 130

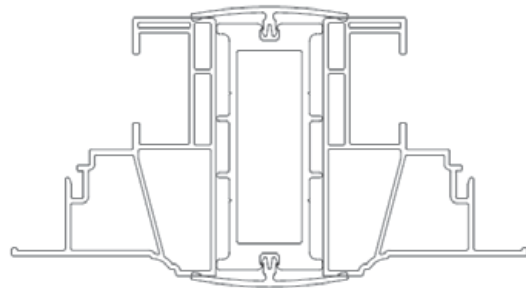

## Recommended Rough Opening for Wood Frame Openings:

Width = Window Width (WW) + 1/2"

Height = Window Height (WH) + 1/2"

# SERIES 130 SLIDERS

## 130 2-Lite Sliders Egress Charts

SERIES 130 2-LITE SLIDER EGRESS CHART

ROUGH OPENING	24"	36"	40"	48"	60"	72"	
EXACT SIZE	23.5"	35.5"	39.5"	47.5"	59.5"	71.5"	
EGRESS WIDTH	8"	14"	16"	20"	26"	32"	
HEIGHT	24"						
	36"						
	48"						
	60"						

SERIES 130 2-LITE SLIDER EGRESS CHART

NOM. SIZE	EGRESS WITH SASH
2020	1.03
2030	1.67
2040	2.36
3020	3.03
3030	1.80
3040	2.97
3050	4.13
3420	2.06
3430	3.39
3440	4.72
3450	6.06
4020	2.57
4030	4.24
4040	5.90
4050	7.57
5020	3.34
5030	5.51
5040	7.67
5050	9.89
6020	4.11
6030	6.78
6040	9.44
6050	12.11













SERIES 130 2-LITE SLIDER COMMODITY EGRESS CHART













Commodity Size	Tip to Tip Size	Exact Size	With Sash	Sq. Feet
22	37 1/4 x 26 1/4	36 x 25	14 1/4 x 20	1.98
23	37 1/4 x 38 5/8	36 x 37 3/8	14 1/4 x 32 3/8	3.20
24	37 1/4 x 50 7/8	36 x 49 5/8	14 1/4 x 44 5/8	4.42
DB22	74 1/4 x 26 1/4	73 x 25	32 3/4 x 20	4.55
DB23	74 1/4 x 38 5/8	73 x 37 3/8	32 3/4 x 32 3/8	7.36
DB24	74 1/4 x 50 7/8	73 x 49 5/8	32 3/4 x 44 5/8	10.15
32	53 3/8 x 26 1/4	52 1/8 x 25	22 1/3 x 20	3.10
33	53 3/8 x 38 5/8	52 1/8 x 37 3/8	22 1/3 x 32 3/8	5.02
34	53 3/8 x 50 7/8	52 1/8 x 49 5/8	22 1/3 x 44 5/8	6.91
1/32	26 3/4 x 26 1/4	25 1/2 x 25	9 x 20	1.25
1/33	26 3/4 x 38 5/8	25 1/2 x 37 3/8	9 x 32 3/8	2.02
1/34	26 3/4 x 50 7/8	25 1/2 x 49 5/8	9 x 44 5/8	2.79
3121	37 1/4 x 25 1/4	36 x 24	14 1/4 x 19	1.88
3131	37 1/4 x 37 1/4	36 x 36	14 1/4 x 31	3.07
3141	37 1/4 x 49 1/4	36 x 48	14 1/4 x 43	4.26
4121	49 1/4 x 25 1/4	48 x 24	20 1/4 x 19	2.67
4131	49 1/4 x 37 1/4	48 x 36	20 1/4 x 31	4.36
4141	49 1/4 x 49 1/4	48 x 48	20 1/4 x 43	6.05
5121	61 1/4 x 25 1/4	60 x 24	26 1/4 x 19	3.46
5131	61 1/4 x 37 1/4	60 x 36	26 1/4 x 31	5.65
5141	61 1/4 x 49 1/4	60 x 48	26 1/4 x 43	7.84
6121	73 1/4 x 25 1/4	72 x 24	32 1/4 x 19	4.26
6131	73 1/4 x 37 1/4	72 x 36	32 1/4 x 31	6.94
6141	73 1/4 x 49 1/4	72 x 48	32 1/4 x 43	9.63

# SERIES 130 SLIDERS

## 130 2-Lite Sliders Commodity Sizes Charts

### SERIES 130 2-LITE SLIDER

MASONRY OPENING	37 3/4"	74 3/4"	53 7/8"	27 1/4"
TIP TO TIP	37 1/4"	74 1/4"	53 3/8"	26 3/4"
EXACT SIZE	36"	73"	52 1/8"	25 1/2"
26"				
26" 1/4"				
25"				
38 3/8"				
38 5/8"				
37 3/8"				
50 5/8"				
50 7/8"				
49 5/8"				

MASONRY OPENING	37 3/4"	49 3/4"	61 3/4"	73 3/4"
TIP TO TIP	37 1/4"	49 1/4"	61 1/4"	73 1/4"
EXACT SIZE	36"	48"	60"	72"
25"				
25" 1/4"				
24"				
37"				
37 1/4"				
36"				
49"				
49 1/4"				
48"				

### SERIES 130 2-LITE SLIDER

















Commodity Size	Masonry Opening Size	Tip to Tip Size	Exact Size
22	37 3/4 x 26	37 1/4 x 26 1/4	36 x 25
23	37 3/4 x 38 3/8	37 1/4 x 38 5/8	36 x 37 3/8
24	37 3/4 x 50 5/8	37 1/4 x 50 7/8	36 x 49 5/8
DB22	74 3/4 x 26	74 1/4 x 26 1/4	73 x 25
DB23	74 3/4 x 38 3/8	74 1/4 x 38 5/8	73 x 37 3/8
DB24	74 3/4 x 50 5/8	74 1/4 x 50 7/8	73 x 49 5/8
32	53 7/8 x 26	53 3/8 x 26 1/4	52 1/8 x 25
33	53 7/8 x 38 3/8	53 3/8 x 38 5/8	52 1/8 x 37 3/8
34	53 7/8 x 50 5/8	53 3/8 x 50 7/8	52 1/8 x 49 5/8
1/32	27 1/4 x 26	26 3/4 x 26 1/4	25 1/2 x 25
1/33	27 1/4 x 38 3/8	26 3/4 x 38 5/8	25 1/2 x 37 3/8
1/34	27 1/4 x 50 5/8	26 3/4 x 50 7/8	25 1/2 x 49 5/8

Commodity Size	Masonry Opening Size	Tip to Tip Size	Exact Size
3121	37 3/4 x 25	37 1/4 x 25 1/4	36 x 24
3131	37 3/4 x 37	37 1/4 x 37 1/4	36 x 36
3141	37 3/4 x 49	37 1/4 x 49 1/4	36 x 48
4121	49 3/4 x 25	49 1/4 x 25 1/4	48 x 24
4131	49 3/4 x 37	49 1/4 x 37 1/4	48 x 36
4141	49 3/4 x 49	49 1/4 x 49 1/4	48 x 48
5121	61 3/4 x 25	61 1/4 x 25 1/4	60 x 24
5131	61 3/4 x 37	61 1/4 x 37 1/4	60 x 36
5141	61 3/4 x 49	61 1/4 x 49 1/4	60 x 48
6121	73 3/4 x 25	73 1/4 x 25 1/4	72 x 24
6131	73 3/4 x 37	73 1/4 x 37 1/4	72 x 36
6141	73 3/4 x 49	73 1/4 x 49 1/4	72 x 48

# SERIES 130 SLIDERS

## 130 3-Lite Sliders Egress Charts

SERIES 130 3-LITE SLIDER EGRESS CHART

ROUGH OPENING		72"	84"	96"	108"
EXACT SIZE		71.5"	83.5"	95.5"	107.5"
EGRESS WIDTH		20.5"	24.5"	28.5"	32.5"
HEIGHT	2.4"				
	36"	6020	7020	8020	9020
	3.6"				
	35.5"	6030	7030	8030	9030
	3.5"				
48"	6040	7040	8040	9040	
4.5"					
59.5"	6050	7050	8050	9050	
5.5"					

SERIES 130 3-LITE SLIDER EGRESS CHART

NOM. SIZE	EGRESS WITH SASH	NOM. SIZE	EGRESS WITH SASH
6020	2.64	8020	3.66
6030	4.22	8030	6.04
6040	6.06	8040	8.42
6050	7.77	8050	10.79
7020	3.15	9020	4.18
7030	5.19	9030	6.89
7040	7.24	9040	9.60
7050	9.28	9050	12.31



# SERIES 130 SLIDERS

## 130 3-Lite Sliders Commodity Size Charts

### SERIES 130 3-LITE SLIDER

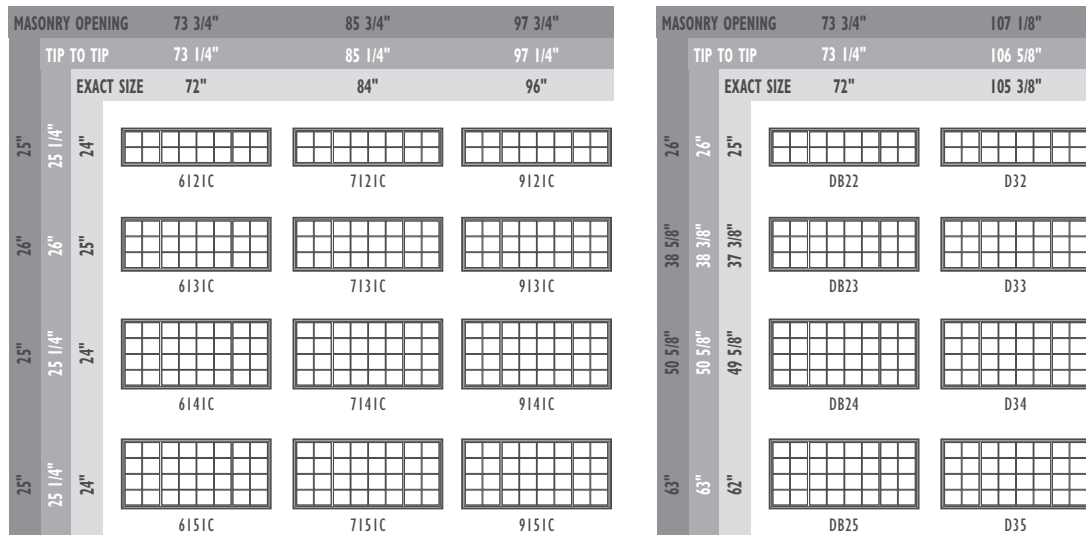

### SERIES 130 3-LITE SLIDER

Commodity Size	Masonry Opening Size	Tip to Tip Size	Exact Size
6121C	73 3/4 x 25	73 1/4 x 25 1/4	72 x 24
6131C	73 3/4 x 37	73 1/4 x 37 1/4	72 x 36
6141C	73 3/4 x 49	73 1/4 x 49 1/4	72 x 48
6151C	73 3/4 x 61	73 1/4 x 61 1/4	72 x 60
DB22	74 3/4 x 26	74 1/4 x 26	73 x 25
DB23	74 3/4 x 38 3/8	74 1/4 x 38 3/8	73 x 37 3/8
DB24	74 3/4 x 50 5/8	74 1/4 x 50 5/8	73 x 49 5/8
DB25	74 3/4 x 63	74 1/4 x 63	73 x 62
7121C	85 3/4 x 25	85 1/4 x 25 1/4	84 x 24
7131C	85 3/4 x 37	85 1/4 x 37 1/4	84 x 36
7141C	85 3/4 x 49	85 1/4 x 49 1/4	84 x 48
7151C	85 3/4 x 61	85 1/4 x 61 1/4	84 x 60

Commodity Size	Masonry Opening Size	Tip to Tip Size	Exact Size
8121C	97 3/4 x 25	97 1/4 x 25 1/4	96 x 24
8131C	97 3/4 x 37	97 1/4 x 37 1/4	96 x 36
8141C	97 3/4 x 49	97 1/4 x 49 1/4	96 x 48
8151C	97 3/4 x 61	97 1/4 x 61 1/4	96 x 60
D32	107 1/8 x 26	106 5/8 x 26	105 3/8 x 25
D33	107 1/8 x 38 3/8	106 5/8 x 38 3/8	105 3/8 x 37 3/8
D34	107 1/8 x 50 5/8	106 5/8 x 50 5/8	105 3/8 x 49 5/8
D35	107 1/8 x 63	106 4/8 x 63	163 3/8 x 62
9121C	108 3/4 x 25	108 1/4 x 25 1/4	107 x 24
9131C	108 3/4 x 37	108 1/4 x 37 1/4	107 x 36
9141C	108 3/4 x 49	108 1/4 x 49 1/4	107 x 48
9151C	108 3/4 x 61	108 1/4 x 61 1/4	107 x 60

### SERIES 130 3-LITE SLIDER COMMODITY EGRESS CHART

Commodity Size	Tip to Tip Size	Exact Size	1/4, 1/2, 1/4	Sq. Feet	1/3, 1/3, 1/3	Sq. Feet
6121C	73 1/4 x 25 1/4	72 x 24	14 2/16 x 19	1.86	20 6/8 x 19	2.73
6131C	73 1/4 x 37 1/4	72 x 36	14 2/16 x 31	3.04	20 6/8 x 31	4.45
6141C	73 1/4 x 49 1/4	72 x 48	14 2/16 x 43	4.22	20 6/8 x 43	6.18
6151C	73 1/4 x 61 1/4	72 x 60	14 2/16 x 55	5.39	20 6/8 x 55	7.90
7121C	85 1/4 x 25 1/4	84 x 24	17 2/16 x 19	2.26	24 6/8 x 19	3.26
7131C	85 1/4 x 37 1/4	84 x 36	17 2/16 x 31	3.69	24 6/8 x 31	5.31
7141C	85 1/4 x 49 1/4	84 x 48	17 2/16 x 43	5.11	24 6/8 x 43	7.37
7151C	85 1/4 x 61 1/4	84 x 60	17 2/16 x 55	6.54	24 6/8 x 55	9.43
8121C	97 1/4 x 25 1/4	96 x 24	20 2/16 x 19	2.66	28 6/8 x 19	3.79
8131C	97 1/4 x 37 1/4	96 x 36	20 2/16 x 31	4.33	28 6/8 x 31	6.18
8141C	97 1/4 x 49 1/4	96 x 48	20 2/16 x 43	6.01	28 6/8 x 43	8.57
8151C	97 1/4 x 61 1/4	96 x 60	20 2/16 x 55	7.69	28 6/8 x 55	10.96
9121C	108 1/4 x 25 1/4	107 x 24	22 14/16 x 19	3.02	32 1/4 x 19	4.27
9131C	108 1/4 x 37 1/4	107 x 36	22 14/16 x 31	4.92	32 1/4 x 31	6.97
9141C	108 1/4 x 49 1/4	107 x 48	22 14/16 x 43	6.83	32 1/4 x 43	9.66
9151C	108 1/4 x 61 1/4	107 x 60	22 14/16 x 55	8.74	32 1/4 x 55	12.36

# SERIES 130 SLIDERS

Series 130 HS vertical diagram

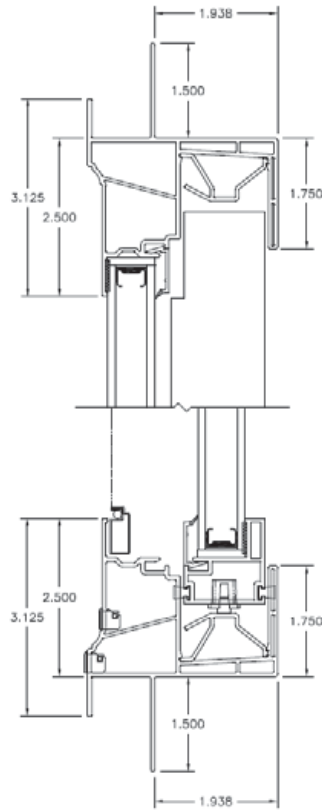

Series 130 horizontal diagram (OX)

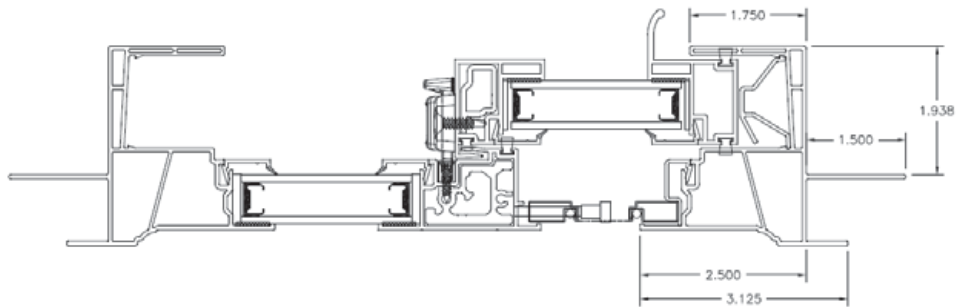

Series 130 horizontal diagram (XOX)

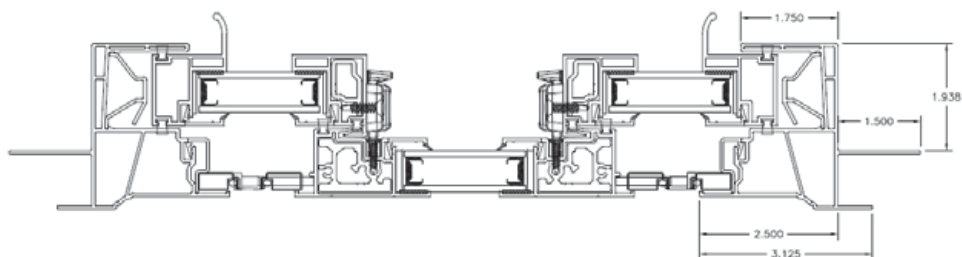

# SERIES 130 SLIDERS

**Series 130 HS horizontal diagram (OX) Box**

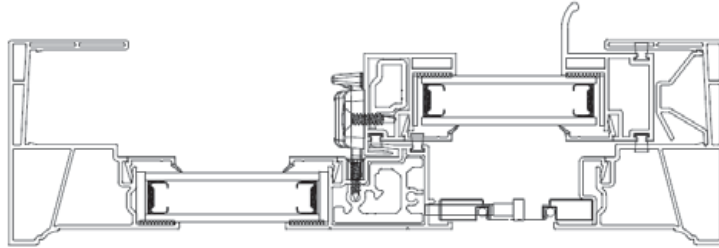

**Series 130 HS horizontal diagram (XOX) Box**

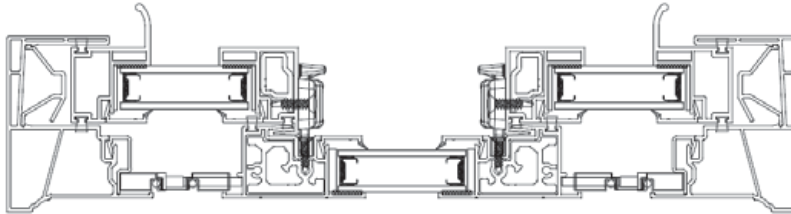

**Series 130 HS horizontal diagram (OX) Fin Only**

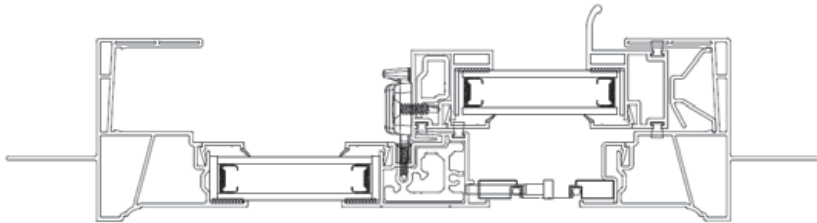

**Series 130 HS horizontal diagram (XOX) Fin Only**

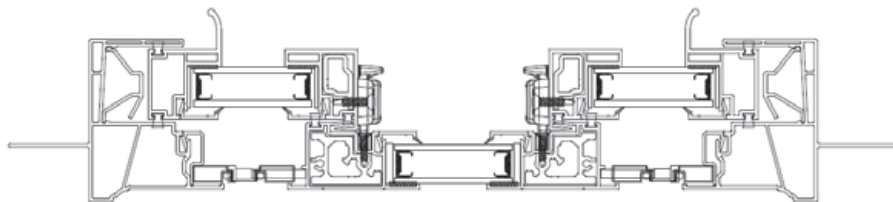

## Features:

- Cam locks are standard.
- Double locks are featured on all windows measuring more than 27 1/4" in height.
- Integrated J-channel assists in the installation of vinyl siding for the Series 151. The Series 161 does not have a J-channel.
- Pre Punched nailing fin allows for faster installation.
- Half screen is standard.
- DP Ratings:  
R30 (window size tested 72" x 48")  
R25 (window size tested 108" x 60") (XOX)

## Custom Options:

- Low-E Glass and Argon Gas
- Ultra Low-E Argon.
- 5/8" or 1" contoured, or 5/8" or 3/4" flat grid.
- Factory mulling of twins, triples and architectural shapes.
- Wood jamb extensions (pre-primed or stainable 4 9/16" and 6 9/16").

## Materials:

- Frame is maintenance free, color stabilized solid vinyl (PVC).
- The screen is comprised of roll formed aluminum frame and fiberglass mesh.
- Glazing method: Glazing tape.

## Mulled Units:

Factory mulling over a slider provides easier installation without extra labor or material costs.

Aluminum reinforcement is standard in factory mulled units.

## Window Construction:

Frame and sashes are fusion welded to protect against air and water infiltration. Fusion adds strength and squareness to the window.

## Wood-Jamb Extension:

The interior wood-jamb extension is available in pre primed or stainable version for your convenience and ease of installation for a frame thickness of either 4 9/16" or 6 9/16".

# SERIES 151/161 SLIDERS

**Series 151 2-Lite and 3-Lite  
vertical diagram**

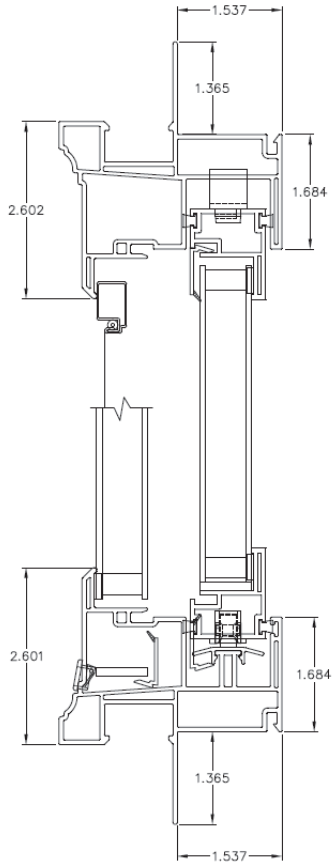

**Series 161 2-Lite and 3-Lite  
vertical diagram**

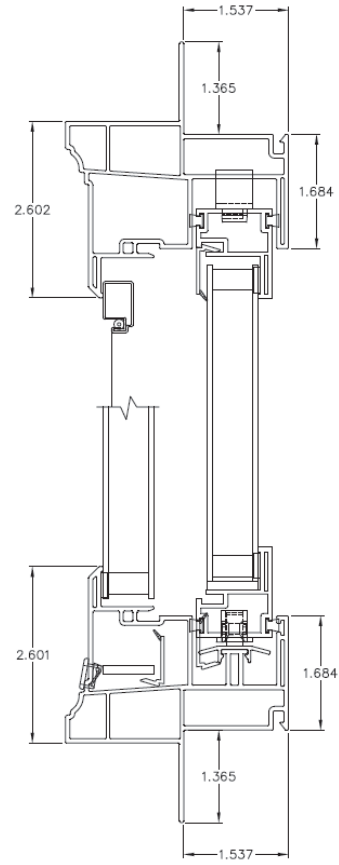

**Series 151 2-Lite  
horizontal diagram**

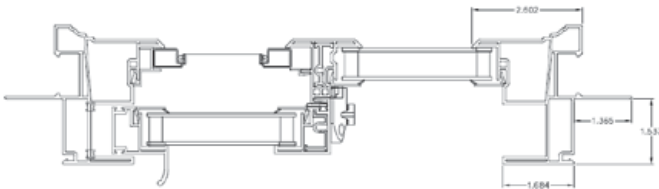

**Series 151 3-Lite  
horizontal diagram**

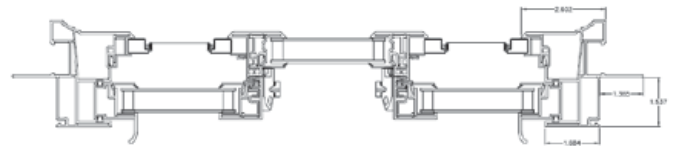

**Series 161 2-Lite  
horizontal diagram**

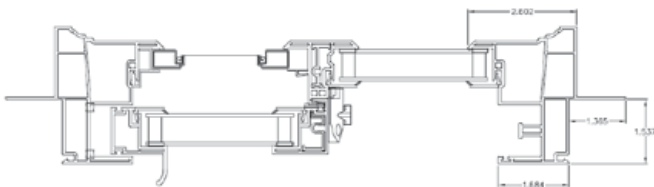



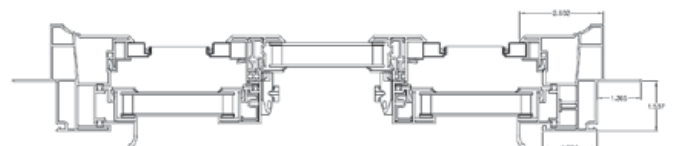

























**Series 161 3-Lite  
horizontal diagram**



# SERIES 151/161 SLIDERS

## Series 151/161 2-Lite Sliders Egress Charts

SERIES 151/161 2-LITE SLIDER EGRESS CHART

ROUGH OPENING		24"	36"	48"	60"	72"	
EXACT SIZE		23.5"	35.5"	47.5"	59.5"	71.5"	
EGRESS WIDTH		7.75"	13.75"	19.75"	25.75"	31.75"	
HEIGHT							
24"	23.5"	18.625"	 2020	 3020	 4020	 5020	 6020
36"	35.5"	30.625"	 2030	 3030	 4030	 5030	 6030
40"	39.5"	34.625"	 2034	 3034	 4034	 5034	 6034
42"	41.5"	36.625"	 2036	 3036	 4036	 5036	 6036
48"	47.5"	42.625"	 2040	 3040	 4040	 5040	 6040
60"	59.5"	57.625"		 3050	 4050	 5050	 6050











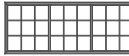
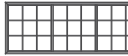
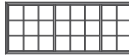





SERIES 151/161 2-LITE SLIDER EGRESS CHART

NOM. SIZE	EGRESS WITH SASH	NOM. SIZE	EGRESS WITH SASH
2020	1.0	5020	3.4
2030	1.7	5030	5.5
2034	1.9	5034	6.3
2036	2.0	5036	6.6
2040	2.4	5040	7.7
3020	1.8	5050	9.9
3030	3.0	6020	4.1
3034	3.4	6030	6.8
3036	3.6	6034	7.7
3040	4.1	6036	8.1
3050	5.3	6040	9.5
4020	2.6	6050	12.1
4030	4.3		
4034	4.8		
4036	5.1		
4040	5.9		
4050	7.6		

# SERIES 151/161 SLIDERS

## Series 151/161 3-Lite Sliders Egress Charts

SERIES 151/161 3-LITE SLIDER EGRESS CHART

ROUGH OPENING		72"	84"	96"	108"
EXACT SIZE		71.5"	83.5"	95.5"	107.5"
EGRESS WIDTH		15.63"	18.63"	21.63"	24.63"
HEIGHT	36"				
	35.5"				
	30.63"				
	40"				
	39.5"				
34.63"					
42"					
41.5"					
36.63"					
48"					
47.5"					
42.63"					
60"					
59.5"					
54.63"					

SERIES 151/161 3-LITE SLIDER EGRESS CHART

NOM. SIZE	EGRESS WITH SASH	NOM. SIZE	EGRESS WITH SASH
6030	4.22	8030	5.92
6034	4.77	8034	6.69
6036	5.04	8036	7.08
6040	5.87	8040	8.24
6050	7.52	8050	10.56
7030	5.07	9030	6.77
7034	5.73	9034	7.65
7036	6.06	9036	8.10
7040	7.05	9040	9.42
7050	9.04		

## Features:

- Double locks are featured on all windows measuring more than 27 1/4" in height.
- There are heavy duty lift rails on each sash.
- Half screen is standard. Full screens are options.
- Integrated J-channel assists in installation of vinyl siding for the Series 451. The Series 461 does not have a J-channel.
- DP Ratings:  
R25 (window size tested 70" x 49")  
R25 (window size tested 96" x 48") (XOX)

## Custom Options:

- Low-E Glass and Argon Gas
- Ultra Low-E Argon.
- 5/8" or 1" contoured, 5/8" or 3/4" flat grid or 1 1/8" Simulated Divided Lite.
- Factory mulling of twins, triples and architectural shapes.
- Wood jamb extensions (pre-primed or stainable 4 9/16" and 6 9/16").
- 3/4" Flat Casing with Bull Nose.

## Materials:

- Frame and sash is maintenance free, color stabilized solid vinyl (PVC).
- All lock rails contain aluminum rebar for additional strength.
- The screen is comprised of an extruded aluminum frame and fiberglass mesh.
- Glazing method: Glazing tape.

## Mulled Units:

Factory mulling over a slider provides easier installation without extra labor or material costs.

## Window Construction:

Frame and sashes are fusion welded to protect against air and water infiltration. Fusion adds strength and squareness to the window.

## Wood-Jamb Extension:

The interior wood-jamb extension is available in pre primed or stainable version for your convenience and ease of installation for a frame thickness of either 4 9/16" or 6 9/16".



# SERIES 451/461 SLIDERS

**Series 45I 2SL 2-Lite and 3SL 3-Lite  
vertical diagram**

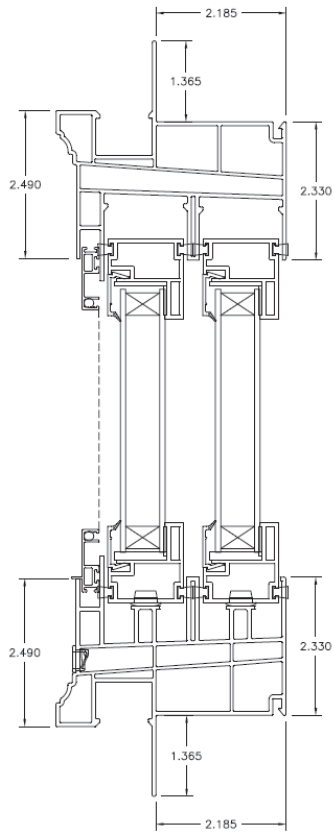

**Series 46I 2SL 2-Lite and 3SL 3-Lite  
vertical diagram**

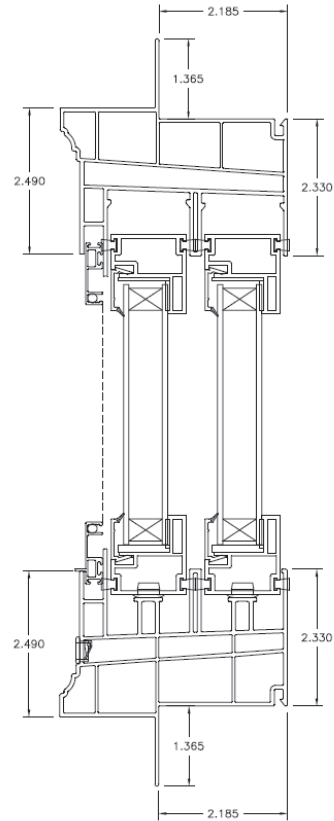

**Series 45I 2-Lite horizontal diagram**

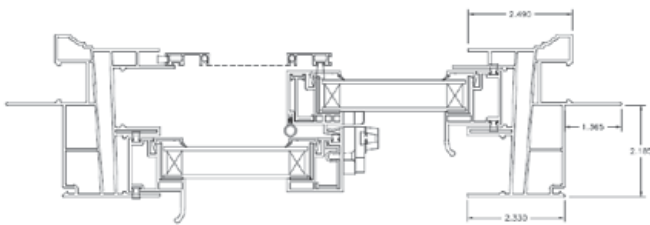

**Series 45I 3-Lite horizontal diagram**

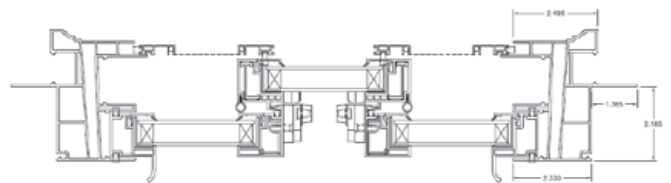

**Series 46I 2-Lite horizontal diagram**

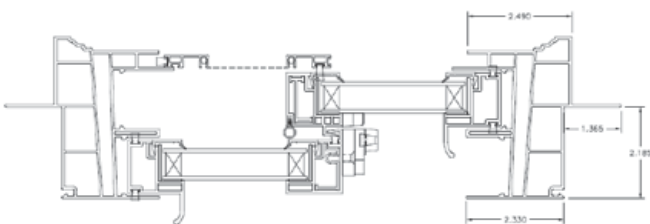



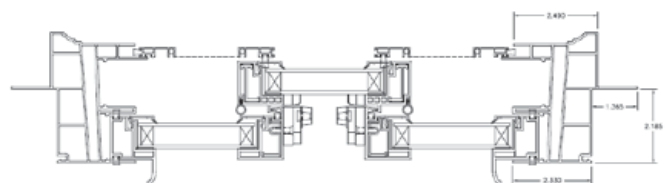



























**Series 46I 3-Lite horizontal diagram**



# SERIES 451/461 SLIDERS

## Series 451/461 2-Lite Slider Egress Charts

SERIES 451/461 2-LITE SLIDER EGRESS CHART

ROUGH OPENING	24"	36"	48"	60"
EXACT SIZE	23.5"	35.5"	47.5"	59.5"
EGRESS WIDTH	6.1875"	12.1875"	18.1875"	24.1875"
HEIGHT				
32"	 2028	 3028	 4028	 5028
38"	 2032	 3032	 4032	 5032
40"	 2034	 3034	 4034	 5034
42"	 2036	 3036	 4036	 5036
46"	 20310	 30310	 40310	 50310
50"	 2042	 3042	 4042	 5042
54"	 2046	 3046	 4046	 5046
62"		 3052	 4052	 5052





















SERIES 451/461 2-LITE SLIDER EGRESS CHART

NOM. SIZE	EGRESS WITH SASH	NOM. SIZE	EGRESS WITH SASH
2028	1.1	4028	3.3
2032	1.4	4032	4.1
2034	1.5	4034	4.3
2036	1.6	4036	4.6
20310	1.7	40310	5.1
2042	1.9	4042	5.6
2046	2.1	4046	6.1
3028	2.2	4052	7.1
3032	2.7	5028	4.4
3034	2.9	5032	5.4
3036	3.1	5034	5.7
30310	3.4	5036	6.1
3042	3.7	50310	6.7
3046	4.1	5042	7.4
3052	4.8	5046	8.1
		5052	9.4

# SERIES 451/461 SLIDERS

## Series 451/461 3-Lite Slider Egress Charts

SERIES 451/461 3-LITE SLIDER EGRESS CHART

ROUGH OPENING	72"	84"	96"	108"
EXACT SIZE	71.5"	83.5"	95.5"	107.5"
EGRESS WIDTH	15.625"	18.625"	21.625"	24.625"
HEIGHT				
32"	31.5"	26.125"		
				
	6028	7028		
38"	37.5"	32.125"		
				
	6032	7032		
40"	39.5"	34.125"		
				
	6034	7034		
42"	41.5"	36.125"		
				
	6036	7036		
46"	45.5"	40.125"		
				
	60310	70310		
50"	49.5"	44.125"		
				
	6042	7042	8042	9042
54"	53.5"	48.125"		
				
	6046	7046	8046	
62"	61.5"	56.125"		
				
	6052	7052	8052	
74"	73.5"	68.125"		
				
	6062			

SERIES 451/461 3-LITE SLIDER EGRESS CHART

NOM. SIZE	EGRESS WITH SASH	NOM. SIZE	EGRESS WITH SASH
6028	2.8	7028	3.3
6032	3.4	7032	4.1
6034	3.6	7034	4.3
6036	3.8	7036	4.6
60310	4.3	70310	5.1
6042	4.7	7042	5.6
6046	5.1	7046	6.1
6052	6.0	7052	7.1
6062	7.2	8042	6.6
		8046	7.1
		8052	8.3
		9042	7.5

## Features:

- Brick mould exterior frame design.
- Collapsible handle folds into assembly cover.
- Superb design and engineering help prevent air and water infiltration.
- Fusion-welded frame and sash ensure weathertight performance.
- Full-perimeter double weather stripping adds extra tightness.
- Narrow profile permits expanded viewing area.
- Concealed hinges and hardware let you open window 90 degrees, for better ventilation and easier cleaning.
- Full screens come standard; mount on interior; remove for easy cleaning.
- Tandem locks come standard on all casements over 32" in height.
- Right or left hinges are available (looking from outside to inside).
- Integrated nailing fin permits easy installation.
- White is standard.
- DP Rating 55  
(window size tested 36" x 72")

## Custom Options:

- Low-E Glass and Argon Gas
- Ultra Low-E Argon.
- 5/8" or 1" contoured, or 5/8" or 3/4" flat grid.
- Almond or Clay colors are an option.
- Special shapes are available.
- Factory mulling available for your convenience and ease of installation.
- Egress Hinge to allow larger area of egress.
- Wood jamb extensions (pre-primed or stainable 4 9/16" and 6 9/16").
- 2" Simulated Meeting Rail.

## Materials:

- Frame and sash are maintenance free, color stabilized solid vinyl (PVC).
- The screen is comprised of an extruded aluminum frame and fiber glass mesh.
- Glazing method: Silicone caulk.

# CASEMENT WINDOWS

SERIES	750 ILT Single
VINYL WALL THICKNESS	0.075" (1.91MM)
GLASS THICKNESS	0.750" (19.05MM)
JAMB THICKNESS	3.250" (82.55MM)
FRAME WIDTH (INTERIOR)	2.625" (66.68MM)
FRAME WIDTH (EXTERIOR)	0.762" (19.35MM)
NAILING FIN SETBACK	2.175" (55.25MM)
NAILING FIN LENGTH	1.25" (31.75MM)
EGRESS WIDTH (REGULAR HINGE)	(WW) - 11 3/4"
EGRESS WIDTH (EGRESS HINGE)	(WW) - 7 1/4"
EGRESS HEIGHT	(WH) - 5 3/16"
DAYLIGHT OPENING WIDTH	(WW) - 6 1/8"
DAYLIGHT OPENING HEIGHT	(WH) - 6 1/8"
SCREEN WIDTH	(WW) - 4 1/4"
SCREEN HEIGHT	(WH) - 4 1/4"
<b>OPTIONS GLASS:</b>	
CLEAR (STANDARD)	•
LOW-E WITH ARGON	•
ULTRA LOW-E WITH ARGON	•
OBSCURE	•
TEMPERED	•
DOUBLE STRENGTH	•
<b>OPTIONS GAS:</b>	
ARGON	•
<b>AVAILABLE SPECIAL SHAPES:</b>	
FULL ROUNDS	QUARTER ROUNDS
HALF ROUNDS	ELLIPTICALS
OCTAGONS	PENTAGONS
TRAPEZOIDS	TRIANGLES
HALF EYEBROWS	EYEBROWS
COLONIAL ARCHES	COLONIAL FLANKERS
	COLONIAL ARCH FLANKERS
<b>COLOR:</b>	
WHITE	•
ALMOND	•
CLAY	•

(WW) = WINDOW WIDTH  
(WH) = WINDOW HEIGHT

## Series 750 vertical diagram

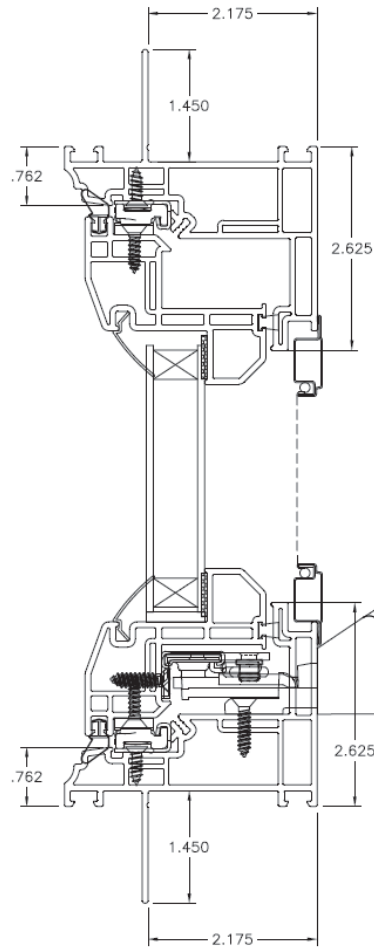

## Series 750 horizontal diagram

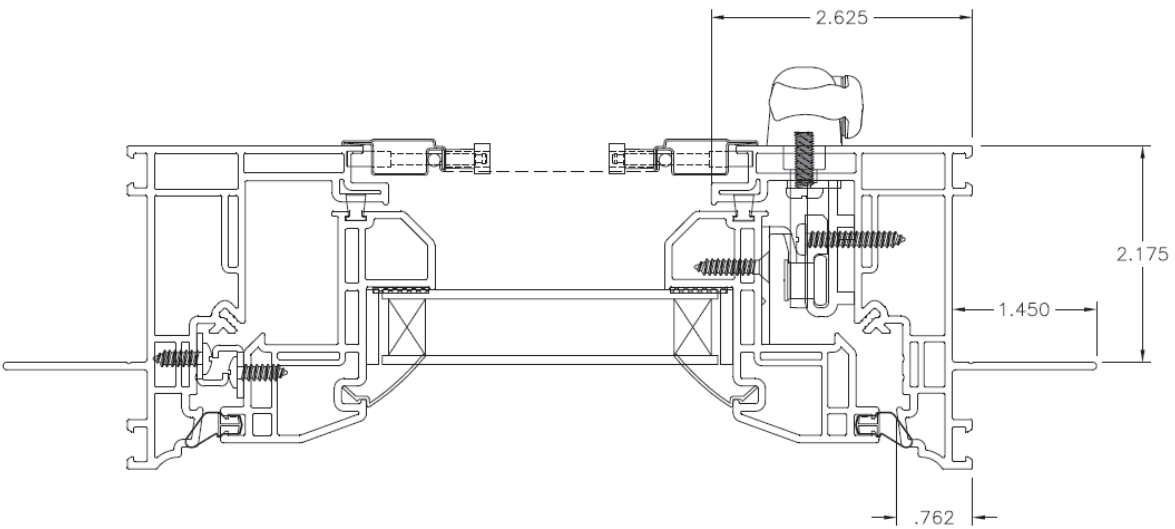

# CASEMENT WINDOWS

## 750 I-Lite Single Casement Size Chart

### SERIES 750 I-LITE SINGLE CASEMENT GRID CHART

ROUGH OPENING	18"	20"	24"	28"	30"	32"	36"
EXACT SIZE	17.5"	19.5"	23.5"	27.5"	29.5"	31.5"	35.5"
24"	1620	1820	2020	2420		2820	3020
36"	1630	1830	2030	2430		2830	3030
42"	1636	1836	2036	2436		2836	3036
48"	1640	1840	2040	2440	2640	2840	3040
54"	1646	1846	2046	2446	2646	2846	3046
60"	1650	1850	2050	2450	2650	2850	3050
66"	1656	1856	2056	2456	2656	2856	3056
68"	1658	1858	2058	2458			

## 750 I-Lite Single Casement Egress Chart





































### SERIES 750 I-LITE SINGLE CASEMENT EGRESS CHART (WITH STANDARD HARDWARE) Egress hardware available.

NOM. SIZE	OPENING SQUARE FEET	NOM. SIZE	OPENING SQUARE FEET	NOM. SIZE	OPENING SQUARE FEET
1620	N/A	2046	N/A	2846	6.6
1630	N/A	2050	N/A	2850	7.5
1636	N/A	2056	N/A	2856	8.3
1640	N/A	2058	N/A	3020	3.0
1646	N/A	2420	2.0	3030	5.0
1650	N/A	2430	3.3	3036	6.0
1656	N/A	2436	4.0	3040	7.0
1658	N/A	2440	4.6	3046	8.0
1820	N/A	2446	5.3	3050	9.0
1830	N/A	2450	6.0	3056	11.0
1836	N/A	2456	6.6		
1840	N/A	2458	6.8		
1846	N/A	2640	5.2		
1850	N/A	2646	6.0		
1856	N/A	2650	6.7		
1858	N/A	2656	7.4		
2020	N/A	2820	2.5		
2030	N/A	2830	4.2		
2036	N/A	2836	5.0		
2040	N/A	2840	5.8		

# CASEMENT WINDOWS

## 750 2-Lite Twin Casement Size Chart

### SERIES 750 2-LITE TWIN CASEMENT GRID CHART

ROUGH OPENING	36"	42"	48"	56"	60"
EXACT SIZE	35.5"	41.5"	47.5"	55.5"	59.5"
24"	 3020	 3620	 4020		 5020
36"	 3030	 3630	 4030		 5030
42"	 3036	 3636	 4036		 5036
48"	 3040	 3640	 4040	 4840	 5040
54"	 3046	 3646	 4046	 4846	 5046
60"	 3050	 3650	 4050	 4850	 5050
66"	 3056	 3656	 4056	 4856	 5056
68"	 3058	 3658	 4058	 4858	 5058



## Features:

- Brick mould exterior frame design.
- Collapsible handle folds into assembly cover.
- Fine-tuned, proven design ensures weathertight performance.
- Fusion-welded frame and sash further reduce air and water infiltration.
- Full-perimeter double weather stripping surrounds 3/4" insulated glass – to provide maximum energy efficiency.
- Interior-mounted full screen and double locks come standard.
- Double locks standard on all awnings.
- Integrated nailing on new construction applications.
- Concealed hinges and operation hardware provide a clean unobstructed view.
- Frames and sashes are fusion welded for a clean look and added strength.
- White is standard.

## Custom Options:

- Low-E Glass and Argon Gas
- Ultra Low-E Argon.
- 5/8" or 1" contoured, or 5/8" or 3/4" flat grid.
- Almond or Clay colors are an option.
- Special shapes are available.
- Factory mulling available for your convenience and ease of installation.
- Wood jamb extensions (pre-primed or stainable 4 9/16" and 6 9/16").

## Materials:

- Frame and sash are maintenance free, color stabilized solid vinyl (PVC).
- Screen is an extruded aluminum frame with fiber glass mesh.
- Glazing method: Silicone caulk.

# AWNING

## Single Vent Awning

## 2 LTH 2-Wide Awning

	19"–27 1/4"	27 3/8"–47 1/8"	47 1/4"–48"	40"–54 1/2"	54 5/8"–86 5/8"	86 3/4"–96"
	1 Vertical	2 Verticals	3 Verticals	1 Vertical	2 Verticals	3 Verticals
27 3/8"–36" 14"–27 1/4"						
2 Horizontals						

## 2 LTV Stacked Awning

## 3 LTV Stacked Awning

	19 – 27 1/4"	27 3/8" – 47 1/8"	47 1/4" – 48"
	1 Vertical	2 Verticals	3 Verticals
33" – 54 1/2"			
54 5/8" – 91"			
2 Horizontals			

	19 – 27 1/4"	27 3/8" – 47 1/8"	47 1/4" – 48"
	1 Vertical	2 Verticals	3 Verticals
45" – 81 3/4"			
81 7/8" – 91"			
2 Horizontals			

## 3 LTH 3-Wide Awning

	60"–81 3/4"	81 7/8"–129 7/8"	130"–144"
	1 Vertical	2 Verticals	3 Verticals
27 3/8"–36" 14"–27 1/4"			
2 Horizontals			

## Dead Lite Over Awning (Equal Lite)

## Dead Lite Over Awning (Cottage & Oriel)

	19 – 27 1/4"	27 3/8" – 47 1/8"	47 1/4" – 48"
	1 Vertical	2 Verticals	3 Verticals
30" – 54 1/2"			
54 5/8" – 91"			
2 Horizontals			

	19 – 27 1/4"	27 3/8"–43 1/8"	43 1/4"–48"
	1 Vertical	2 Verticals	3 Verticals
33" – 91"			
33" – 91"			
1 Hor. / 3 Hor. Cottage			
3 Hor. / 2 Hor. Oriel			

# SLIDING PATIO DOORS

## Features:

- Pre-assembled for easy installation with reversible moving panel.
- Pre-punched nail fin for easy new construction applications simply removes for replacement projects.
- 7/8" tempered glass panels for energy efficiency and safety.
- Limited lifetime warranty.
- White enamel handle with lock is standard for the 311.
- Color matched handle with keyed lock is standard for the 312 and 332.
- The 311 is available in 5', 6', and 6'4" widths, while the 312 and 332 models are available in 5', 6', 6'4", 8', 9', and 12' widths.
- The 332 has a 8'0" height available in 5', 6', and 6'4" widths.
- The 311 comes in white only, while it is standard for the 312 and 332.
- A factory installed screen is optional for the 311 and is standard with the 312 and 332.
- The 312 and 332 has a jamb depth of 4 9/16"; 311 jamb depth is 5 5/8".
- The 332 has a DP 50 rating for the 5068, 5080, 6068 and 6080 models.
- The 332 has a multi-point lock mechanism.
- White is standard.

## Custom Options:

- Low-E Glass and Argon Gas.
- Ultra Low-E Argon.
- Non-reflective Glass.
- 5/8" or 1" contoured, or 5/8" or 3/4" flat grid between the panes for easy glass cleaning; 1 1/8" simulated divided lite (for 312 & 322).
- 4 9/16" pre-primed and 6 9/16" extender kits are available for the 311 and 312 while 6 9/16" extender kits are available for the 332.
- Brass grid is available for the 312 and the 332.
- The 312 and 332 are available with an interior wood finish (on white exterior only).
- The 312 is available with Bronze exterior (on white interior only).
- Exclusive options for the 332 include hide-rite screen, foot bolt lock, and field applied flat or brick mould J-channel.
- Custom sizes are available (for 312 & 332).
- Almond and Clay colors available (for 312 & 332).
- Blinds Between The Glass (for 312 & 332).
- Polished Brass and Brushed Nickel Handle.

## Materials:

- Frame and sash are maintenance free, color stabilized solid vinyl (PVC).
- The sash and fixed meeting rail contain steel rebar for added strength.
- Glazing method: Glazing tape.

## Structural Performance

MODEL	TEST SIZE	AIR	WATER	LOAD	DESIGN PRESSURE
311/312	70 3/4" X 79 1/2"	0.12	6.75	52.50	SGD-R35 71 X 80
312	94 3/4" X 79 1/2"	0.12	4.50	37.50	SGD-R25 95 X 80
332	72" X 96"	0.16	7.50	75.00	SGD-R50 72 X 96
312 Custom	70 3/4" X 81 1/2"	0.12	6.75	52.50	SGD-DP35 70 3/4 X 81 1/2
332 Custom	70 3/4" X 81 1/2"	0.16	7.50	75.00	SGD-DP50 70 3/4 X 81 1/2

# SLIDING PATIO DOORS

SERIES	311	312	332
VINYL WALL THICKNESS FRAME	0.070" (1.78MM)	0.070" (1.78MM)	0.090" (2.29MM)
VINYL WALL THICKNESS SASH	0.080" (2.03MM)	0.080" (2.03MM)	0.080" (2.03MM)
GLASS THICKNESS	0.813" (20.65MM)	0.813" (20.65MM)	0.813" (20.65MM)
JAMB THICKNESS	4.563" (115.90MM)	4.563" (115.90MM)	5.633" (143.08MM)
FRAME WIDTH EXTERIOR	1.00" (25.40MM)	1.00" (25.40MM)	1.132" (28.70MM)
FRAME WIDTH INTERIOR	1.718" (43.64MM)	1.718" (43.64MM)	2.00" (50.80MM)
NAILING FIN LENGTH	1.0" (25.40MM)	1.0" (25.40MM)	1.671" (42.44MM)
NAIL FIN SETBACK	3.368" (85.55MM)	3.368" (85.55MM)	4.563" (115.90MM)
EGRESS WIDTH	5' = 22 1/2" 6' = 28 1/2" 6'4" = 32"	5' = 22 1/2" 6' = 28 1/2" 6'4" = 32" 8' = 40 1/2"	5' = 22 3/4" 6' = 28 3/4" 6'4" = 32 3/8" 8' = 40 3/4"
EGRESS HEIGHT	76"	76"	6'8" = 75 1/2" 8' = 95 1/2"
SCREEN SIZE	5068 = 30" x 77 1/16" 6068 = 36" x 77 1/16" 6468 = 38" x 77 1/16" 8068 = 48" x 77 1/16"	5068 = 30" x 77 1/16" 6068 = 36" x 77 1/16" 6468 = 38" x 77 1/16" 8068 = 48" x 77 1/16"	5068 = 30 1/2" x 77 1/2" 6068 = 36 1/2" x 77 1/2" 6468 = 38 1/2" x 77 1/2" 8068 = 48 1/2" x 77 1/2" 5080 = 30 1/2" x 93 1/2" 6080 = 36 1/2" x 93 1/2" 6480 = 38 1/2" x 93 1/2"
OPTIONS GLASS:			
CLEAR (STANDARD)	•	•	•
LOW-E WITH ARGON	•	•	•
ULTRA LOW-E WITH ARGON	•	•	•
OPTIONS GAS:			
ARGON	•	•	•
COLOR:			
WHITE	•	•	•
ALMOND		•	•
CLAY		•	•
NATURAL OAK INTERIOR		•	•
HILLSIDE OAK INTERIOR		•	•
BRONZE EXTERIOR		•	

## Thermal Performance







GLASS/GRID	312 STANDARD SIZE		312 CUSTOM SIZE		332 STANDARD SIZE		332 CUSTOM SIZE	
	U-Value	SHGC	U-Value	SHGC	U-Value	SHGC	U-Value	SHGC
DS Clear Glass No Grid	0.48	0.64	0.48	0.64	0.47	0.63	0.47	0.63
DS Low-E Glass No Grid	0.33	0.31	0.33	0.31	0.33	0.30	0.33	0.30
DS Low-E/Argon Glass No Grid	0.30	0.30	0.30	0.30	0.30	0.30	0.30	0.30
DS Ultra Low-E/Argon No Grid	0.30	0.23	0.30	0.23	0.30	0.22	0.29	0.22
DS Clear Glass with Grid	0.48	0.56	0.48	0.56	0.47	0.55	0.47	0.55
DS Low-E Glass with Grid	0.33	0.27	0.33	0.27	0.33	0.27	0.33	0.27
DS Low-E/Argon Glass with Grid	0.30	0.27	0.30	0.27	0.30	0.27	0.30	0.27
DS Ultra Low-E/Argon with Grid	0.30	0.20	0.30	0.20	0.30	0.20	0.29	0.20
DS Clear Glass with SDL	0.48	0.45	0.48	0.49	0.47	0.49	0.47	0.49
DS Low-E Glass with SDL	0.33	0.27	0.33	0.27	0.33	0.27	0.33	0.27
DS Low-E/Argon Glass with SDL	0.30	0.27	0.30	0.27	0.30	0.27	0.30	0.27
DS Ultra Low-E/Argon Glass with SDL	0.29	0.20	0.29	0.20	0.29	0.20	0.29	0.20

# SLIDING PATIO DOORS

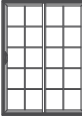
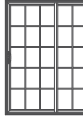
## 311, 312, and 332 Sliding Patio Doors Size Chart

ROUGH OPENING	60"	72"	76"	96"	108"	144"	140"
EXACT SIZE WITHOUT FIN	58.75	70.75"	74.75"	94.75	107.5"	143.5"	139.875"
OPENING WIDTH	59.5"	71.5"	75.5"	95.5"	108.25"	144.25"	140.625"
HEIGHT							
	80"	79.5"	80.0"				
	96"	95.5"	96.0"				

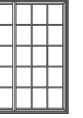
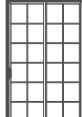
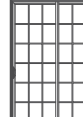

						
5068	6068	6468	8068	9068	12068 (3 PANEL)	12068 (4 PANEL)
						
5080	6080	6480				

Notes: 1. 311 only available in 5068, 6068 and 6468 sizes.  
 2. 5080, 6080 and 6480 only available in 332.

### Wood-Jamb Extension Kits:

The interior wood-jamb extension kit is available in pre primed pine or stainable for your convenience and ease of installation. The extension creates an overall frame thickness of 4 9/16" or 6 9/16". Note: Model #332 has a 4 9/16" jamb as standard.

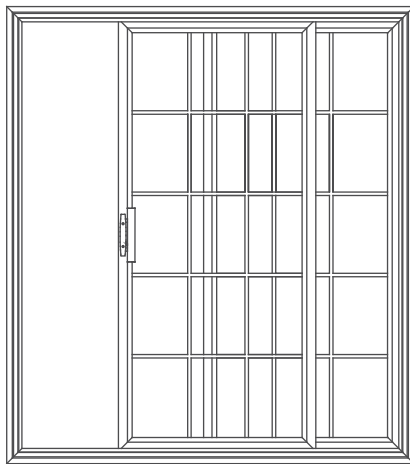

INTERIOR VIEW OF DOOR WITH COLONIAL GRID PARTIALLY OPEN

### Recommended Rough Opening:

Width = Door Width (DW) + 3/4"  
 Height = Door Height (DO) + 1/2"

# SLIDING PATIO DOORS

**Model 311 vertical diagram**

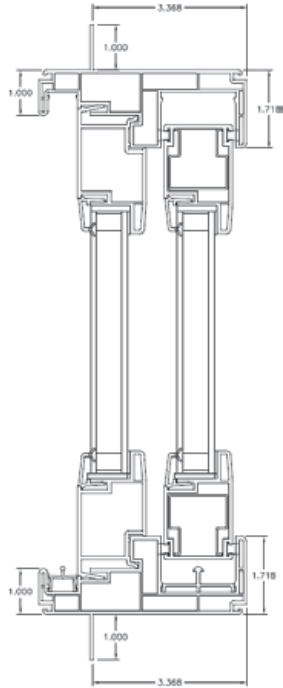

**Model 312 vertical diagram**

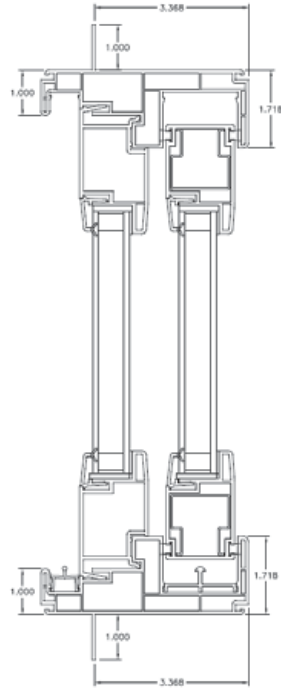

**Model 332 vertical diagram**

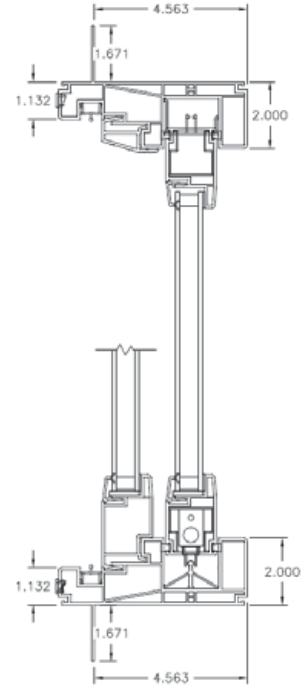

**Model 311 horizontal diagram**

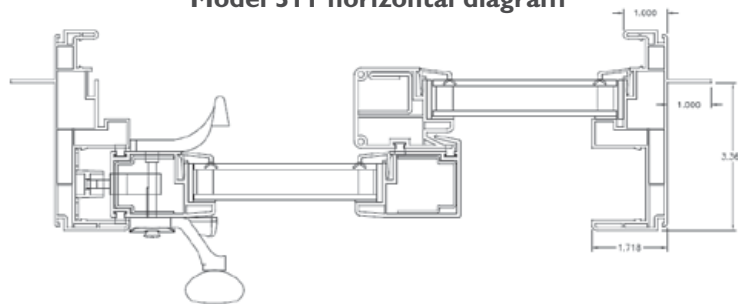

**Model 312 horizontal diagram**

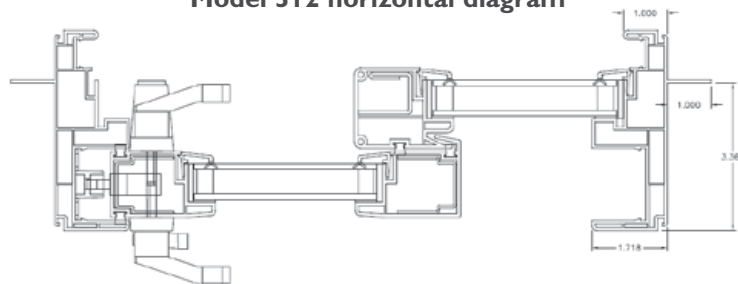

**Model 332 horizontal diagram**

